

# Solid state Physics & Miscellaneous Topics

There are two types of solids :

(i) Amorphous

(ii) Crystalline  $\rightarrow$  internal structure can be replicated in terms of some fundamental units called crystals, therefore it has ordered arrangement of atoms.

## Crystal Structure Determination

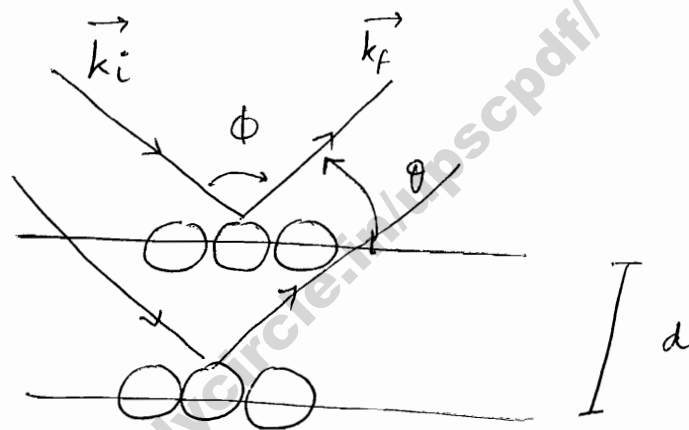

Now,  $2\theta + \phi = \pi$

$$\theta = \left( \frac{\pi - \phi}{2} \right)$$

Also,  $2d \sin \theta = n\lambda$  for interference constructively

Now we also also, for diffraction,  $|\vec{k}_f| = |\vec{k}_i|$

Also  $\vec{k}_f = \vec{k}_i + \vec{G}$  where  $G = \left( \frac{2\pi}{d} \right)$

Laue Equations

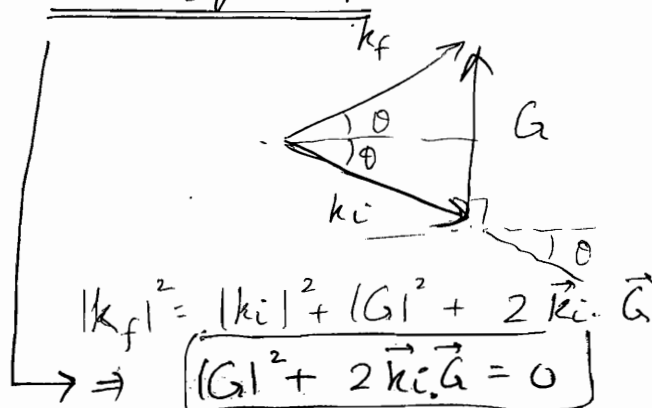

and direction is  $\perp$  to plane of diffraction

Its called Reciprocal Lattice Vector.

$$\Rightarrow \left(\frac{2\pi}{d}\right)^2 + 2 \cdot \frac{2\pi}{\lambda} \cdot \frac{2\pi}{d} \cdot \cos(90^\circ + \theta) = 0$$

$$\Rightarrow \frac{2\pi}{d} + 2 \cdot \frac{2\pi}{\lambda} \cdot \sin \theta = 0$$

$$\Rightarrow \boxed{\lambda = 2d \sin \theta}$$

Also note  $\left(\frac{G}{k}\right) = \frac{2\pi}{d} \cdot \frac{\lambda}{2\pi} = \left(\frac{\lambda}{d}\right) = \begin{matrix} 2 \sin \theta \\ \text{(for 1st order} \\ \text{interference)} \end{matrix}$

## Tools of Crystal structure determination

Optical / Conventional Microscopy is not sufficient as their resolving power is quite low. Remember that

Resolving Power  $\propto \frac{1}{\lambda}$        $\lambda \approx 4000 - 7800 \text{ \AA}$

For  $e^-$  scattering,  $\lambda$  is quite low  $\Rightarrow$  resolving power is high

There are two types of  $e^-$  microscopy based on scattering:

- ① Transmission  $e^-$  microscopy
- ② Scanning  $e^-$  microscopy

Remember that  $d$  is of the order of  $\lambda$  i.e. the structure to be determined should be of order of  $\lambda$  used, if more  $\lambda \Rightarrow$  low resolving power, structure can't be determined.

## Properties of solids

- ① Magnetic Properties
  - Ferro
  - para
  - Dia
  - permeability  $\mu_r \mu_0$
  - Magnetism

# Basic BJT Amplifier Configurations

(2)

## (1) Common Emitter Configuration

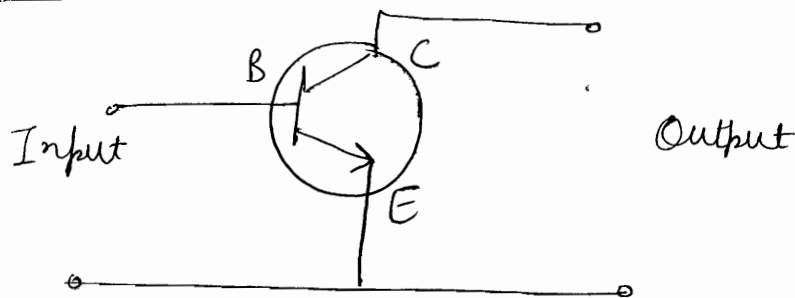

Emitter terminal is common to both input & output signals. Adv.

- (1) Medium input impedance
- (2) Medium output impedance
- (3) high voltage gain
- (4) high current gain

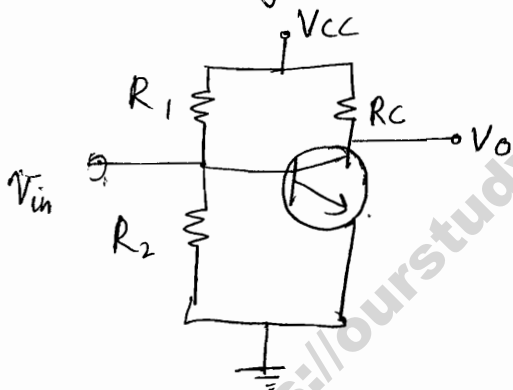

## (2) Common Base Configuration

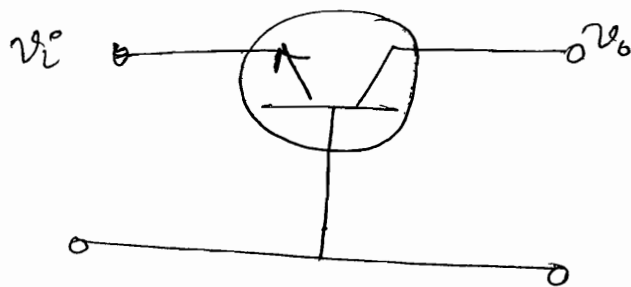

Adv

- (1) Used freq for RF applications
- (2) ~~low~~ low input resistance
- (3) high output impedance
- (4) Unity or less current gain
- (5) high voltage gain

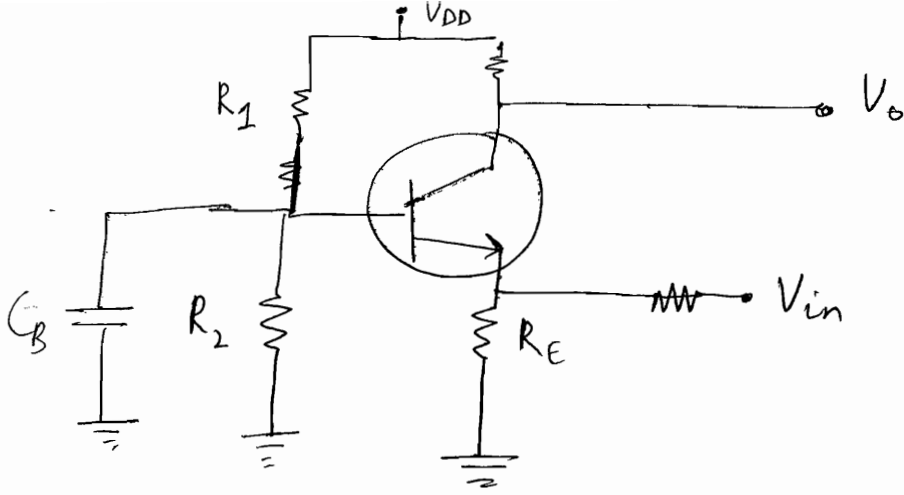

③ Common Collector Configuration

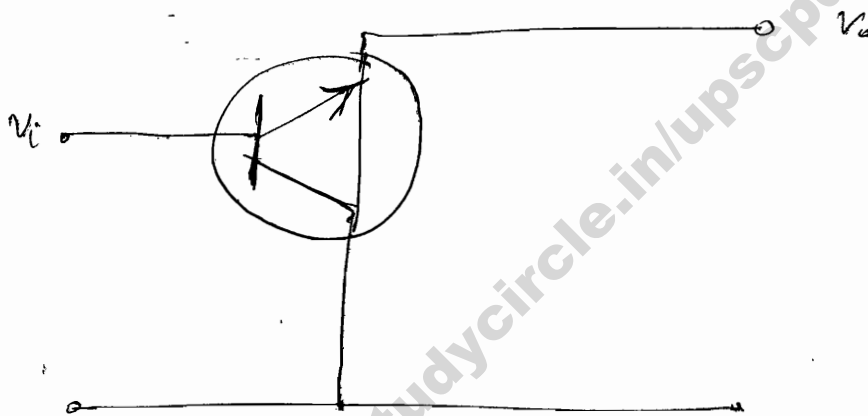

Also called emitter follower because the input signal applied at the base is "followed" quite closely at the emitter with a voltage gain close to unity. It has

- ① high input impedance
- ② low output impedance
- ③ high current gain
- ④ unity or less voltage gain

Circuit is used as buffer, converting impedance or for feeding or driving long cables or low impedance loads.

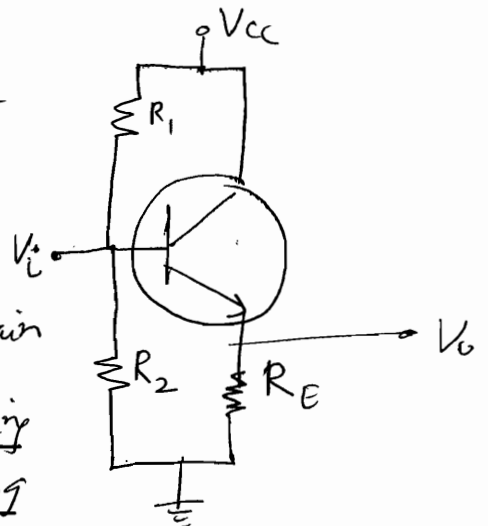

# Analysis

(3)

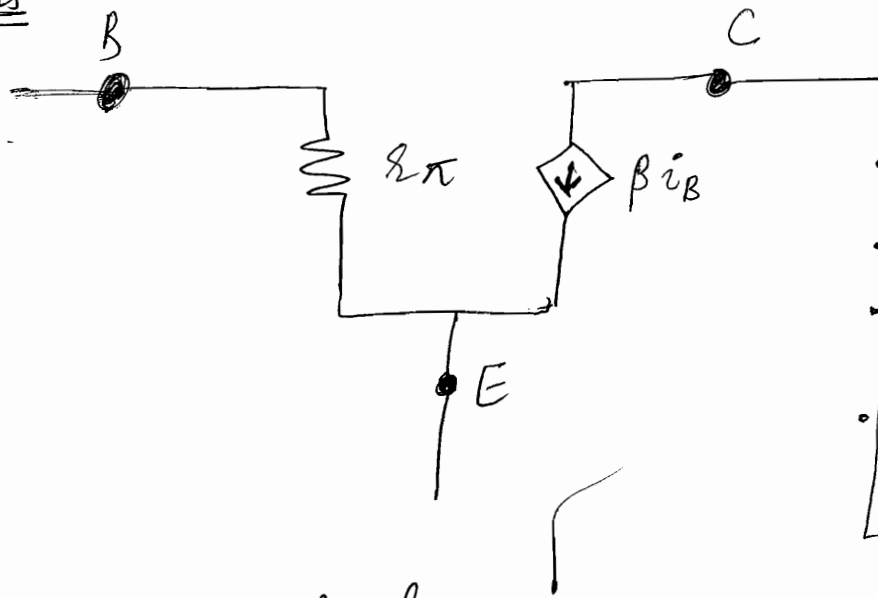

- $I_E = I_C + I_B$
- $V_{BE} = 0.7V$
- $\beta = \left(\frac{I_C}{I_B}\right)$   $\alpha = \left(\frac{I_C}{I_E}\right)$
- $r_{\pi} = \left(\frac{0.025}{I_B}\right)$

• Small-signal equivalent model of BJT

- First, find Q point via D.C. Analysis
- Then replace DC by ground, BJT by small signal model and find out gain,  $R_{in}$ ,  $R_{out}$ .

<https://ourstudydrive.in/pscpdf/>

### ③ Cubic Crystals

#### ① Simple Cubic

no. of nearest neighbours for an atom  
 \* Coordination no = 6



\* Packing Fraction =  $\frac{\text{Volume of Atoms within unit cell}}{\text{Volume of Unit Cell}}$

[Polonium]

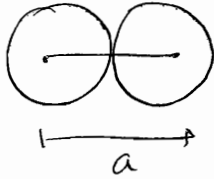

$$a = 2r$$

No. of atoms in 1 unit cell =  $\frac{1}{8} \times 8$   
 =  $\boxed{1}$

$$\Rightarrow P.F. = \frac{\frac{4}{3} \pi r^3 \times 1}{a^3}$$

$$= \frac{\frac{4}{3} \pi \left(\frac{1}{8}\right)}{\left(\frac{1}{8}\right)} = \boxed{0.52}$$

#### ② Body Centred Cubic

[Na] \* Coordination number = 8  
 [K] \* Packing Fraction

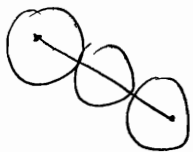
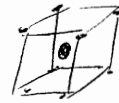

$$\sqrt{3} a = 4r$$

$$P.F. = \frac{\boxed{2} \times \frac{4}{3} \pi r^3}{a^3}$$

$$= \frac{8 \pi \frac{3\sqrt{3}}{64}}{3} = \boxed{0.68}$$

#### ③ Face Centred Cubic

[Cu] \* Coordination number = 12  
 [Ag] \* Packing Fraction  
 [Au]



12 (4+4+4)  
 corner ↓ ↓  
 Fc of top Fc of bottom

$$\sqrt{2} a = 4r$$

$$P.F. = \frac{\boxed{4} \times \frac{4}{3} \pi r^3}{a^3}$$

$$= \frac{16 \pi \frac{2\sqrt{2}}{64}}{3} = \boxed{0.74}$$

..... ABC ABC ABC.....

# Hexagonal Close Packing

Coordination No. =  $6+3$   
 (4) = 12

(Mg  
Zn)

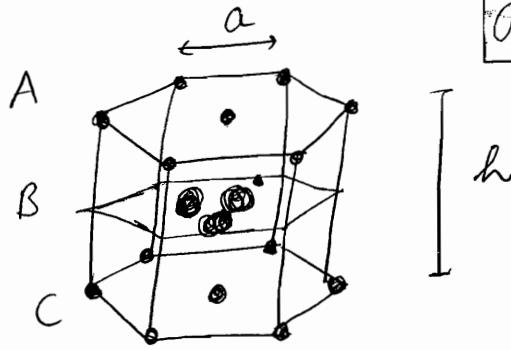

$a = 2r$

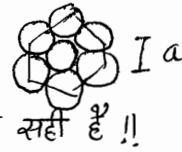

(...ABABAB...)

→ Centre of 1<sup>st</sup> layer A lies exactly over void of 2<sup>nd</sup> layer B

→ Centre sphere and spheres of 2<sup>nd</sup> layer B are in touch.

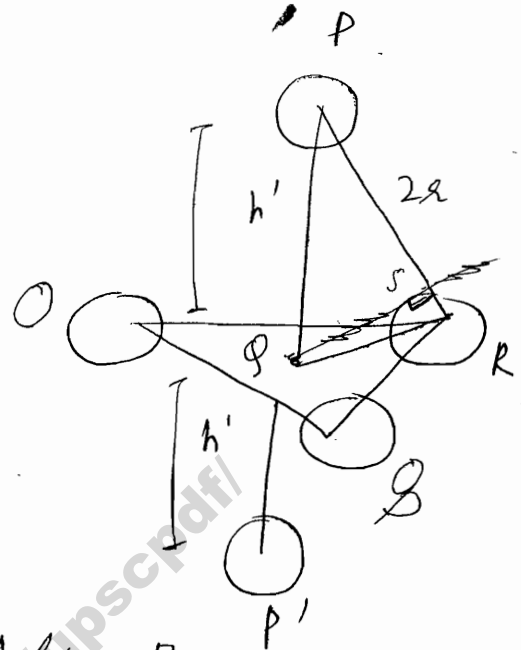

⇒  $\triangle OQR$  is equilateral triangle

$OR = 2r$

$\Rightarrow 2 OR \cos 30^\circ = OR$   
 $\Rightarrow OR = \frac{r}{\cos 30^\circ} = \left(\frac{2r}{\sqrt{3}}\right)$

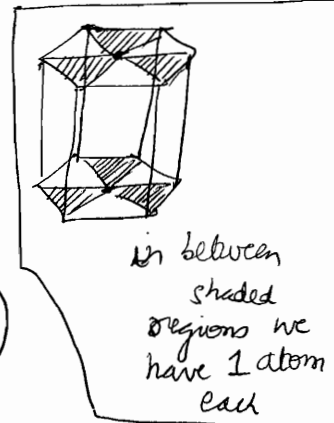

~~∴ In SCPT~~  
~~OR = 2r~~

$\Rightarrow OP = \sqrt{(2r)^2 - OR^2} = \sqrt{4r^2 - \frac{4r^2}{3}}$   
 $= \sqrt{\frac{8r^2}{3}} = \frac{2\sqrt{2}r}{\sqrt{3}}$

$\Rightarrow h = 2h' = 2OP = \frac{4\sqrt{2}r}{\sqrt{3}}$

$\Rightarrow \text{Volume of Crystal} = 6 \times \frac{\sqrt{3}}{4} a^2 \times h$

$= 6 \times \frac{\sqrt{3}}{4} \times 4r^2 \times \frac{4\sqrt{2}r}{\sqrt{3}} = 24\sqrt{2}r^3$

Volume of atoms =  $6 \times \frac{4}{3} \pi r^3$

$\Rightarrow \text{P.F.} = 74\%$

<https://ourstudycircle.in/upscpdf/>



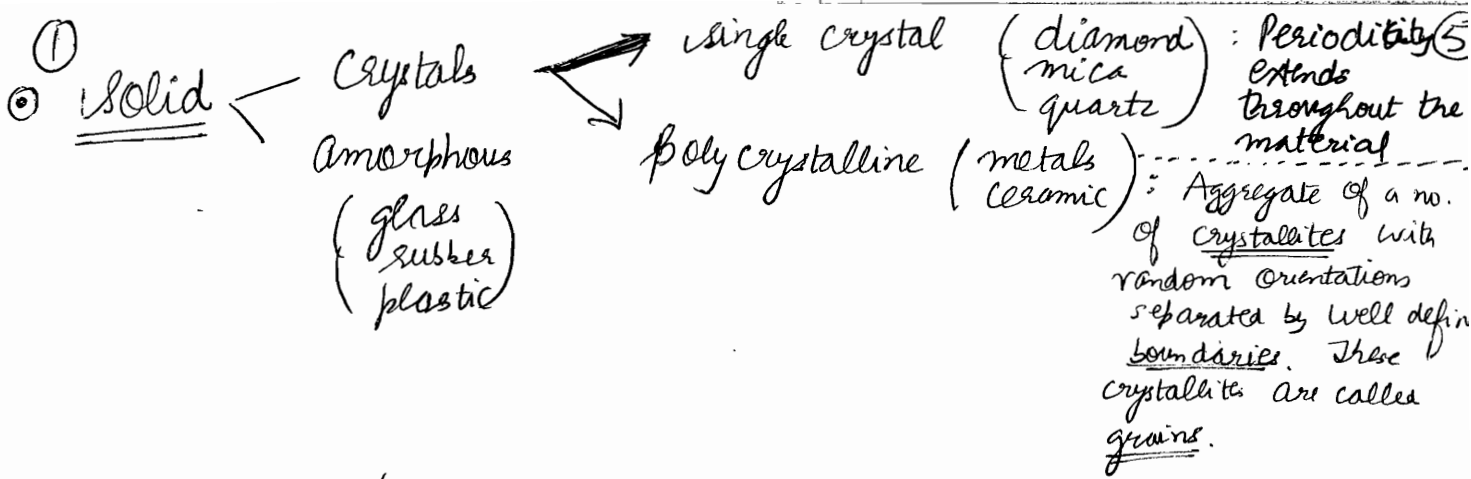

② Point lattice / Space lattice :  $\infty$  no. of imaginary points in 3-dimensional space, each having identical surrounding

③ Pattern Unit : Lattice contains small group of points, called pattern unit, which repeats itself in all directions, by means of a translation operator  $\vec{T}$

$$\vec{T} = n_1 \vec{a} + n_2 \vec{b} + n_3 \vec{c}$$

④  $(n_1, n_2, n_3) \in \mathbb{Z} \Rightarrow$  Primitive translation vector  
 $\Rightarrow$  Primitive unit cell

if fraction  $\Rightarrow$  non-primitive

⑤ Unit Cell : Building block for construction of complete lattice. Primitive Unit Cell is the smallest volume cell.

⑥ Wigner-Seitz Cell :  $\left\{ \begin{array}{l} - \text{Join nearby lattice points} \\ - \text{draw } \perp \text{ bisectors} \\ - \text{volume enclosed is Wigner-Seitz Cell} \end{array} \right.$

⑦  $\vec{a}, \vec{b}, \vec{c}$  : Basis vectors or Crystal Axis

⑧ Component of Crystal Lattice  $\left\{ \begin{array}{l} \text{Space lattice (14)} \\ \text{Basis} \left\{ \begin{array}{l} \text{Monoatomic (Coffee)} \\ \text{Complex (Biological)} \end{array} \right. \end{array} \right.$   
 (Atom or group of atom that takes the place of space lattice points)

① Symmetry Operations : Transformation that yield the same crystal.

—	Rotation	
—	Reflection	(about a plane (3D) or a line (2D))
—	Translation	$\vec{T}$
—	Inversion	$(x, y, z) \rightarrow (-x, -y, -z)$

② Multiplicity of Rotation Axis

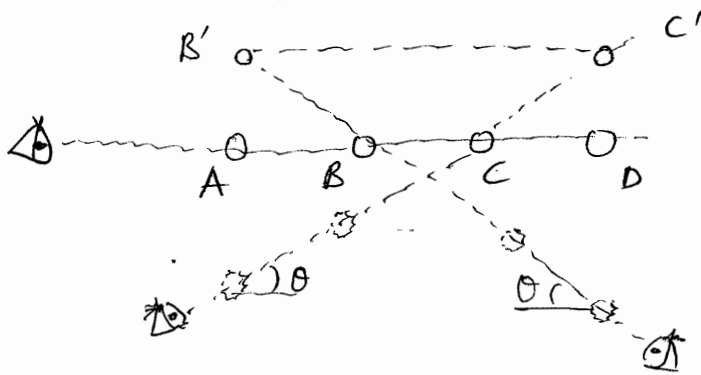

Let distance between lattice points =  $T$

We must have,  $B'C' = m BC$

$$T + 2T \cos \theta = mT$$

$$\cos \theta = \left( \frac{m-1}{2} \right)$$

$$-1 \leq \frac{m-1}{2} \leq 1$$

$$-1 < m < 3$$

$$\theta = \frac{2\pi}{1}, \frac{2\pi}{2}, \frac{2\pi}{3}, \frac{2\pi}{4}, \frac{2\pi}{6}$$

Multiplicity =  $\left( \frac{2\pi}{\theta} \right)$

$\Rightarrow n = 1, 2, 3, 4, 6$

For a given crystal,  $n$  can take values from above 5 values.

③ The symmetry operations lead to different kinds of space lattice :

5 : 2 - dimensions

14 : 3 - dimensions

14 '3-D' lattice are defined by 6 lattice parameters :

Angles :  $\alpha, \beta, \gamma$

dimensions :  $a, b, c$

along with

P	(Primitive Cell)
F	(Face Centred Cell)
I	(body Centred Cell)

② Numbers of effective lattice points belonging to a cell is ⑥ given by

$$N = N_c + \left(\frac{N_f}{2}\right) + \left(\frac{N_e}{8}\right) \quad c: \text{corner}$$

③ Lattice directions and planes

→ direction given by  $[h, k, l]$  where  $h, k, l \in \mathbb{Z}$   
 (Bracket)  
 negative direction is represented by  $\bar{h}$ .

→ angle between 2 directions

$$\cos \theta = \frac{hh' + kk' + ll'}{\sqrt{h^2 + k^2 + l^2} \sqrt{h'^2 + k'^2 + l'^2}}$$

→ plane orientation is given by Miller Indices  $(h, k, l)$   
 (parenthesis)

$h, k, l \in \mathbb{Z}$  and are simplified (to integer) reciprocals of intercepts to crystal axes. Intercepts are measured in  $(a, b, c)$  units.

Interplanar spacing  $d = \frac{1}{\sqrt{\left(\frac{h}{a}\right)^2 + \left(\frac{k}{b}\right)^2 + \left(\frac{l}{c}\right)^2}}$  (in general)

Interplanar spacing  $d = \frac{a}{\sqrt{h^2 + k^2 + l^2}}$

for cubic lattice ( $a=b=c$ )

④ Simple Crystal Structures

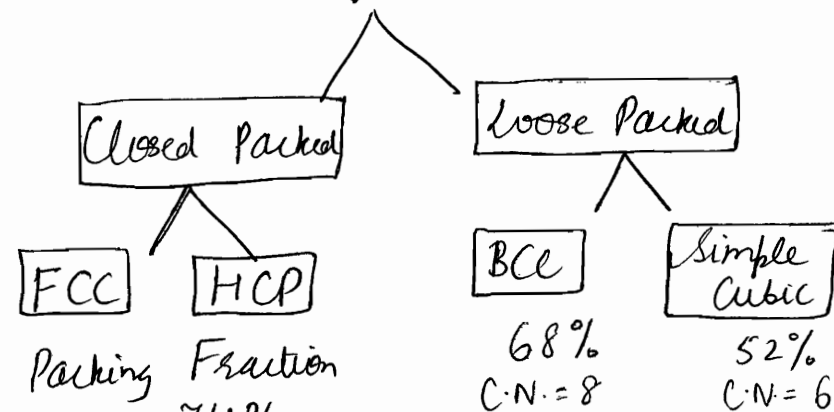

Coordination number = 12

Composite Systems

examples include

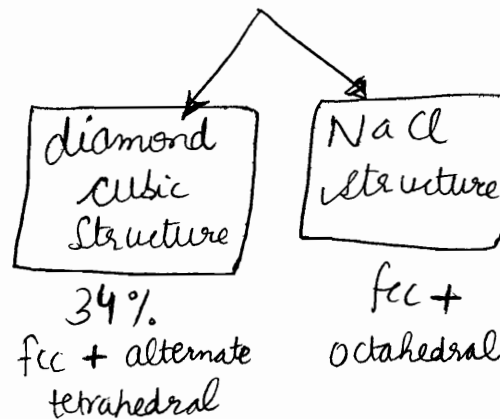

## ◉ Diamond Cubic (dc) structure

✓ Packing Efficiency: 34% (if both atoms are same)

✓ Coordination number: 4

✓ Nearest neighbour distance =  $\frac{\sqrt{3} a}{4}$

✓ 2 Basis

1<sup>st</sup>: fcc position (effectively: 4 atoms)

2<sup>nd</sup>: 4 atoms at alternate tetrahedral sites (effectively: 4)

eg. - Si (Both basis: Si atoms)

- Ge ( " " : Ge " )

- Diamond ( " " : C " )

- ZnS ( Zn: 1<sup>st</sup>, S: 2<sup>nd</sup> )  
(Zinc Blende)

✓ It can also be seen as interpenetration of 2 fcc lattices.

## ◉ NaCl structure

✓ Coordination Number: 6

✓ 2 Basis

1<sup>st</sup>: fcc position (4)

2<sup>nd</sup>: octahedral voids (4)

✓ can be viewed as interpenetrating fcc lattices

④ All angle  $(\alpha, \beta, \gamma) = 90$  ( इन्हें working आसान है, यही आँगे ) ⑦

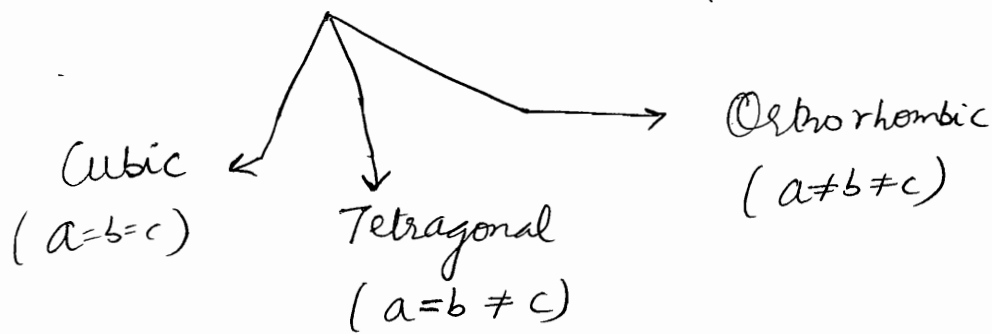

Q A plane makes intercepts of 1, 2 and 0.5 Å. on the crystallographic axes of an orthorhombic crystal with  $a:b:c = 3:2:1$ . Determine the Miller Indices of the plane

A/ Let length of basis axes vectors be 3Å, 2Å and 1Å  
 $\Rightarrow$  Intercepts in terms of basis vectors =  $\left(\frac{1}{3}\right), \left(\frac{2}{2}\right), \left(\frac{0.5}{1}\right)$   
 $= \frac{1}{3}, 1, \frac{1}{2}$

$\Rightarrow$  Reciprocal of intercepts = (3, 1, 2)

$\Rightarrow$  Miller Indices of plane are (3, 1, 2)

### X-ray diffraction

#### ① Theory (scattering + Interference)

When an atomic electron is irradiated by a beam of monochromatic X-rays, it starts vibrating with frequency equal to that of incident beam. Since an accelerated charge emits radiations, the vibrating electrons present inside a crystal become source of secondary radiations having same frequency as incident X-rays. These secondary

X-rays spread out in all directions. Its called Scattering of X-rays. These secondary waves interfere Constructive only in certain directions, leading to formation of a diffraction pattern, called LAUE'S PATTERN.

## ② ANALYSIS

### ① Bragg's Treatment (Reflection + Interference)

The direction of diffraction lines can be accounted for if X-rays are considered to be reflected from a set of parallel atomic planes followed by constructive interference of resulting reflected rays.

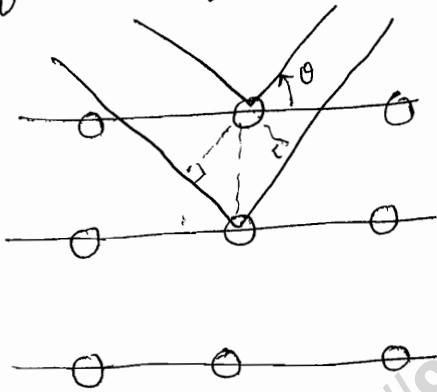

$$2d \sin \theta = n \lambda$$

Bragg's law

Intensity of reflected lines decreases with increase in value of  $n$  or  $\theta$ .  $n_{\max}$  found by  $\sin \theta = 1$ .

### ② Von Laue's Treatment

Von Laue considered the scattering of X rays by individual atoms in the crystal, followed by their interference. Note that here we are not considering reflection from an atomic plane.  $\Rightarrow$  its a more general treatment.

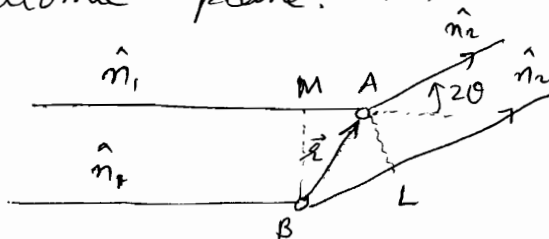

$$\textcircled{5} \quad \Delta = BL - AM = \vec{r} \cdot \hat{n}_2 - \vec{r} \cdot \hat{n}_1 = \vec{r} \cdot (\hat{n}_2 - \hat{n}_1) \quad \textcircled{8}$$

$$= \underline{\underline{\vec{r} \cdot \vec{N}}} \quad (\text{where } \vec{N} = \hat{n}_2 - \hat{n}_1)$$

$$\Rightarrow \Delta\phi = \frac{2\pi}{\lambda} (\vec{r} \cdot \vec{N})$$

In a 3-d axes,  $\vec{r}$  may coincide with any of the 3 crystallographic axis,  $\vec{a}$ ,  $\vec{b}$  and  $\vec{c}$ .  $\therefore$  for occurrence of diffraction maxima,

$$\frac{2\pi}{\lambda} (\vec{a} \cdot \vec{N}) = 2\pi h' = 2\pi n h$$

$$\frac{2\pi}{\lambda} (\vec{b} \cdot \vec{N}) = 2\pi k' = 2\pi n k$$

$$\frac{2\pi}{\lambda} (\vec{c} \cdot \vec{N}) = 2\pi l' = 2\pi n l$$

where  $h', k', l'$  represent 3 integers, having HCF as  $n$ .

Note that  $(h, k, l)$  represent the miller indices of a plane which happens to be a reflecting plane. (proof on next page) whose normal is  $\vec{N}$ .

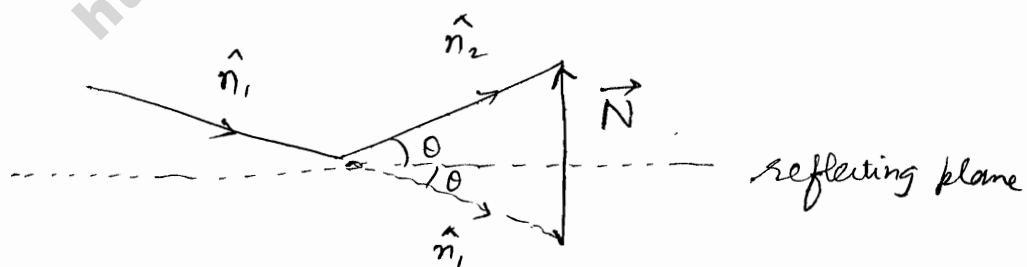

$$|\vec{N}| = 2 \sin \theta$$

Let  $\alpha, \beta, \gamma$  be angles between scattering normal  $\vec{N}$  and crystallographic axis  $\vec{a}, \vec{b}$  and  $\vec{c}$ .

$$\Rightarrow \vec{a} \cdot \vec{N} = 2a \sin \theta \cos \alpha$$

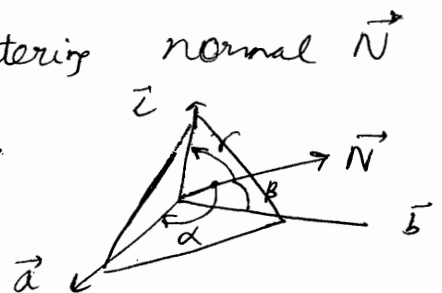

Hence we can write

$$\left. \begin{aligned} \vec{a} \cdot \vec{N} &= 2a \sin\theta \cos\alpha = n\lambda \\ \vec{b} \cdot \vec{N} &= 2b \sin\theta \cos\beta = n\lambda \\ \vec{c} \cdot \vec{N} &= 2c \sin\theta \cos\gamma = n\lambda \end{aligned} \right\} \text{Laue's equations}$$

1) We know interplanar spacing, for plane  $(h, k, l)$  is given by

$$d = \frac{a}{h} \cos\alpha = \frac{b}{k} \cos\beta = \frac{c}{l} \cos\gamma$$

Hence, we get:  $\boxed{2d \sin\theta = n\lambda}$

2) For fixed  $\theta$ , directional cosines  $\cos\alpha$ ,  $\cos\beta$ ,  $\cos\gamma$  of scattering normal are proportional to  $\left(\frac{h}{a}\right)$ ,  $\left(\frac{k}{b}\right)$  and  $\left(\frac{l}{c}\right)$

Also, we know, directional cosines of normal to any arbitrary plane  $(h, k, l)$  are proportional to  $\frac{h}{a}, \frac{k}{b}, \frac{l}{c}$

Hence, scattering normal  $\vec{N}$  is same as normal to the plane  $(h, k, l)$  i.e. the arbitrary plane  $(h, k, l)$  happens to be reflecting plane.

### © EXPERIMENTAL METHODS

- 1) Laue Method
- 2) Rotating Crystal Method
- 3) Powder Method

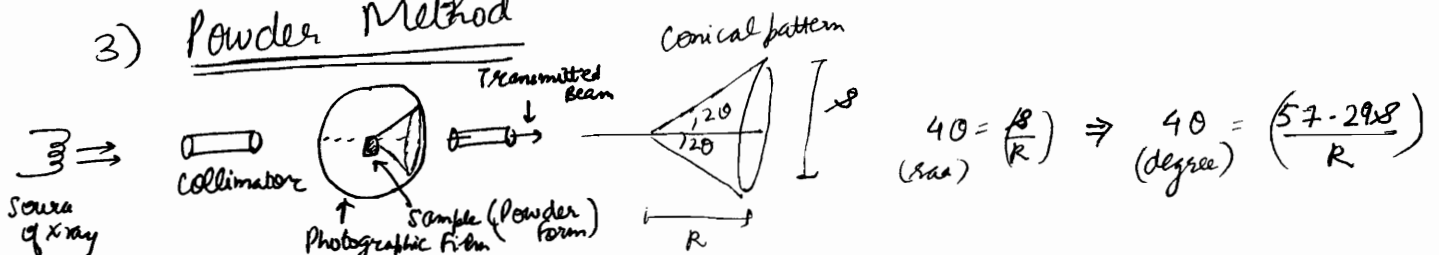



## (D) RECIPROCAL LATTICE

(9)

(6)

Diffraction of x-rays occur from various sets of parallel planes having different orientations (slopes) and different interplanar spacings. Therefore, Ewald developed Reciprocal Lattice i.e.

- 1) Each point in reciprocal lattice corresponds to particular set of parallel planes of the direct lattice.
- 2) Distance of reciprocal lattice point from an arbitrarily fixed origin, is inversely proportional to the interplanar spacing of corresponding parallel planes of the direct lattice.
- 3) Volume of unit cell of reciprocal lattice is inversely proportional to volume of corresponding unit cell of direct lattice.

### Reciprocal lattice Vector

$a^*$  : magnitude = reciprocal of interplanar spacing  
 $d_{hkl}$

direction = normal to (hkl) plane

$$a^* = \frac{1}{d_{hkl}} \hat{n}$$

Note that a vector drawn from the origin to any point in the reciprocal lattice is a Reciprocal lattice Vector.

$$a^* = 2\pi \left[ \frac{\vec{b} \times \vec{c}}{\vec{a} \cdot (\vec{b} \times \vec{c})} \right]$$

$$b^* = 2\pi \left[ \frac{\vec{c} \times \vec{a}}{\vec{a} \cdot (\vec{b} \times \vec{c})} \right]$$

$$c^* = 2\pi \left[ \frac{\vec{a} \times \vec{b}}{\vec{a} \cdot (\vec{b} \times \vec{c})} \right]$$

$a, b, c$  : Translation vector of direct lattice  
 $a^*, b^*, c^*$  : of reciprocal lattice

∴ Hence, every crystal is associated with 2 types of lattice: direct lattice and reciprocal lattice.

$$\text{Also, } \vec{a}^* \cdot (\vec{b}^* \times \vec{c}^*) = \frac{1}{\vec{a} \cdot (\vec{b} \times \vec{c})}$$

$$T = n_1 \vec{a} + n_2 \vec{b} + n_3 \vec{c}$$

$$\underline{\underline{G = h \vec{a}^* + k \vec{b}^* + l \vec{c}^*}} \quad \text{reciprocal lattice vector}$$

$$e^{i(G \cdot T)} = e^{i 2\pi [n_1 h + n_2 k + n_3 l]} = 1$$

### Simple Cubic

$$\begin{aligned} \vec{a} &= a \hat{i} & \vec{a}^* &= \left(\frac{2\pi}{a}\right) \hat{i} & , & \vec{b}^* &= \left(\frac{2\pi}{a}\right) \hat{j} \\ \vec{b} &= a \hat{j} & \vec{c}^* &= \left(\frac{2\pi}{a}\right) \hat{k} \\ \vec{c} &= a \hat{k} \end{aligned}$$

Hence reciprocal lattice is also simple cubic.

### BCC lattice

$$\begin{aligned} \vec{a} &= \frac{a}{2} (\hat{i} + \hat{j} - \hat{k}) & \vec{a}^* &= \frac{2\pi}{a} (\hat{i} + \hat{j}) \\ \vec{b} &= \frac{a}{2} (-\hat{i} + \hat{j} + \hat{k}) & \vec{b}^* &= \frac{2\pi}{a} (\hat{j} + \hat{k}) \\ \vec{c} &= \frac{a}{2} (\hat{i} - \hat{j} + \hat{k}) & \vec{c}^* &= \frac{2\pi}{a} (\hat{k} + \hat{i}) \end{aligned}$$

negative

(रक पीछे वाले में गड़ बड़)

केवल पहले की working दिखाओ बाकी बोले cyclically आ जाएंगे

missing

Primitive translation vectors of FCC lattice

### FCC lattice

$$\begin{aligned} \vec{a} &= \frac{a}{2} (\hat{i} + \hat{j}) \\ \vec{b} &= \frac{a}{2} (\hat{j} + \hat{k}) \\ \vec{c} &= \frac{a}{2} (\hat{k} + \hat{i}) \end{aligned} \quad \left. \begin{aligned} \vec{a}^* &= \frac{2\pi}{a} (\hat{i} + \hat{j} - \hat{k}) \\ \vec{b}^* &= \frac{2\pi}{a} (\hat{j} + \hat{k} - \hat{i}) \\ \vec{c}^* &= \frac{2\pi}{a} (\hat{k} + \hat{i} - \hat{j}) \end{aligned} \right\} \begin{array}{l} \text{Primitive} \\ \text{translation} \\ \text{vectors of} \\ \text{BCC} \\ \text{lattice} \end{array}$$

# ⑦ Bragg's law in Reciprocal Lattice

96

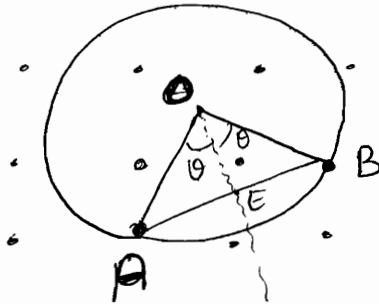

Ewald construction

In reciprocal lattice, take any point  $O$  (not necessarily a lattice point)

draw  $\vec{OA}$  of length  $(\frac{1}{\lambda})$

in direction of incident X-ray beam s.t. it terminates on a lattice point  $A$

Draw circle from  $O$  with  $OA$  radius and define coordinate system with  $A$  at origin!

If  $B$  intersects the circle, whose coordinates are  $(h', k', l')$

$$\Rightarrow |\vec{AB}| = \left( \frac{n}{d_{hkl}} \right) : \text{reciprocal lattice vector} = (nh, nk, nl)$$

$$AB = 2AE = 2OA \sin \theta = \frac{2 \sin \theta}{\lambda}$$

$$\Rightarrow \frac{n}{d_{hkl}} = \frac{2 \sin \theta}{\lambda}$$

$$\Rightarrow \boxed{n\lambda = 2d_{hkl} \sin \theta}$$

2<sup>nd</sup> form

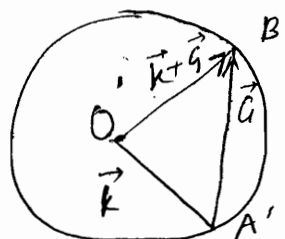

Magnified Ewald Construction

$$A'O' = \left( \frac{2\pi}{\lambda} \right) \text{ write } A'O' = \vec{k}$$

$A'B'$ : reciprocal lattice vector  $\vec{G}$

$$|O'A'| = |O'B'| \Rightarrow (\vec{k} + \vec{G})^2 = k^2 \Rightarrow \boxed{G^2 + 2\vec{k} \cdot \vec{G} = 0}$$

The 2<sup>nd</sup> form is used to Brillouin Zones.

## (E) Brillouin Zones

From Ewald Construction, we know all the  $\vec{k}$  values for which reciprocal lattice points intersect the Ewald sphere are Bragg reflected.

A Brillouin Zone is locus of all those  $k$ -values in the reciprocal lattice which are Bragg reflected.

Simple square lattice (not cubic)

$$\begin{aligned} \vec{a} &= a \hat{i} & \vec{a}^* &= \left(\frac{2\pi}{a}\right) \hat{i} & \vec{G} &= \frac{2\pi}{a} (h \hat{i} + k \hat{j}) \\ \vec{b} &= a \hat{j} & \vec{b}^* &= \left(\frac{2\pi}{a}\right) \hat{j} \end{aligned}$$

using 2<sup>nd</sup> form of Bragg's equation,

$$2 \vec{k} \cdot \vec{G} + G^2 = 0$$

$$h k_x + h k_y = -\frac{\pi}{a} (h^2 + k^2)$$

Consider all possible combinations of  $(h, k)$ , we get

$$h = \pm 1, k = 0 \Rightarrow k_x = \pm \left(\frac{\pi}{a}\right), k_y \in \mathbb{R}$$

$$h = 0, k = \pm 1 \Rightarrow k_y = \pm \left(\frac{\pi}{a}\right), k_x \in \mathbb{R}$$

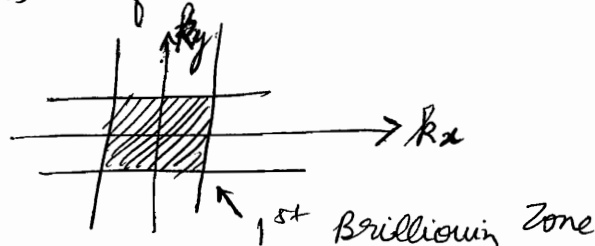

Using other values of  $(h, k)$  obtain other zones

Boundaries of Brillouin zones represent loci of  $k$ -values that are Bragg reflected  $\Rightarrow$  hence, they are reflecting planes:

- 1<sup>st</sup> zone : 1<sup>st</sup> order reflection
- 2<sup>nd</sup> zone : 2<sup>nd</sup> order reflection

$(h, k) = (\pm 1, \pm 1)$

⑧ BCC

$$\vec{a}^* = \left(\frac{2\pi}{a}\right) (\hat{i} + \hat{j})$$

$$\vec{b}^* = \left(\frac{2\pi}{a}\right) (\hat{j} + \hat{k})$$

$$\vec{c}^* = \left(\frac{2\pi}{a}\right) (\hat{k} + \hat{i})$$

(remember we are taking reciprocal lattice here)

⑨c

$$\vec{G} = \frac{2\pi}{a} \left( (h+l) \hat{i} + (h+k) \hat{j} + (h+l) \hat{k} \right)$$

Using different combinations like  $(\pm 1, 0, 0)$ ,  $(0, \pm 1, 0)$ ,  $(0, 0, \pm 1)$   
we get 12 vectors viz.  $\frac{2\pi}{a} (\pm \hat{i} \pm \hat{j})$ ,  $\frac{2\pi}{a} (\pm \hat{j} \pm \hat{k})$ ,  $\frac{2\pi}{a} (\pm \hat{k} \pm \hat{i})$

⇒ Rhombic Dodecahedron  
(12 faced)

FCC

$$\vec{a}^* = \frac{2\pi}{a} (\hat{i} + \hat{j} - \hat{k})$$

$$\vec{b}^* = \frac{2\pi}{a} (-\hat{i} + \hat{j} + \hat{k})$$

$$\vec{c}^* = \frac{2\pi}{a} (\hat{i} - \hat{j} + \hat{k})$$

$$\vec{G} = \frac{2\pi}{a} \left[ (h-k+l) \hat{i} + (h+k-l) \hat{j} + (-h+k+l) \hat{k} \right]$$

We get Truncated Octahedron

⑨ Allowed  $h, k, l$  values for reflections

simple cubic : all possible values of  $h, k, l$

$$h^2 + k^2 + l^2 \text{ :- } 1 : 2 : 3 : 4 :$$

BCC : even values of  $h+k+l$

$$h^2 + k^2 + l^2 \text{ :- } 2 : 4 : 6 : 8$$

$(2, 0, 0)$   $(3, 0, 0)$   $(0, 2, 2)$

FCC : all odd or all even values of  $h, k, l$

$$h^2 + k^2 + l^2 \text{ :- } 3 : 4 : 8 : 11 : \dots$$

$(1, 1, 1)$   $(2, 0, 0)$   $(2, 2, 0)$   $(3, 1, 1)$

Remember (1)  $d_{hkl} = \frac{a}{\sqrt{h^2 + k^2 + l^2}}$  for cubic crystals  
 $a$ : lattice parameter

(2)  $a^3 = \left( \frac{n' M}{N \rho} \right)$

$\left( \rho = \frac{n' \left( \frac{M}{N} \right)}{a^3} \right)$

$n'$ : effective atoms in a cubic crystal (FCC: 4)

$M$ : Molecular weight

$N$ : Avogadro

$\rho$ : density of crystal

$\left( \frac{M}{N} \right)$ : mass of 1 atom

## Bond Theory of Solids

• If we assume free e<sup>-</sup> i.e. no bound of potential, then

$\psi = e^{ikx}$

$E = \left( \frac{\hbar^2 k^2}{2m} \right), \underline{k} \in (-\infty, \infty)$

But in order to understand Band structure of solids, we have to consider a periodically varying potential

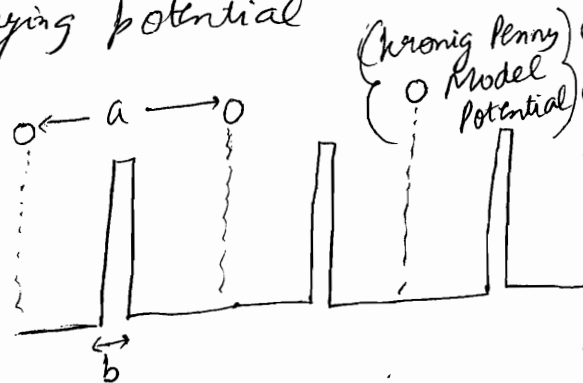
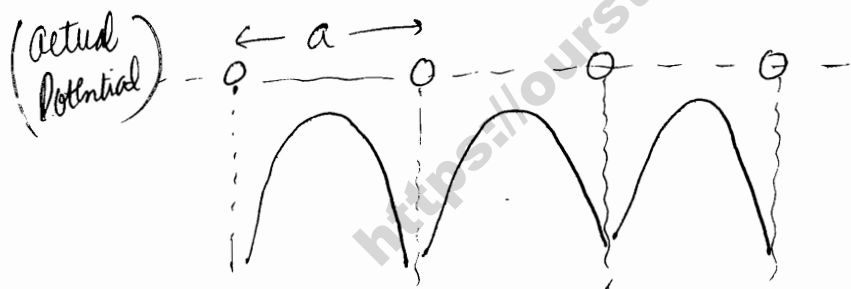

- < Read Band Structure from H.C. Verma >
- < Qualitative formation of Band gaps & >
- < Classification of solids into conductors, insulators >
- < and semiconductors. >

The movement of e<sup>-</sup> in a region of periodically varying potential, with the periodicity of the lattice, caused by ion-cores situated at the lattice points, which results in diffraction of electrons by the lattice  $\left( \lambda = \frac{h}{p} \right)$  if  $\approx a$ .

The electron undergoes Bragg's reflection.

# (9) Schrödinger Solution of Kronig Penny Potential (9d)

Eigenfunction of a free electron travelling wave

$$\psi(x) = e^{\pm ikx} \quad \text{where } k = \frac{2\pi}{\lambda} \quad \text{ie. propagation const.}$$

For a periodic potential with periodicity  $a$ ,

$$\psi(x) = U_k(x) e^{\pm ikx} \quad \text{where } U_k(x+a) = U_k(x) = U_k(x+na)$$

This is called Bloch Theorem.

$U_k(x)$  depends on particular potential and value of  $k$ .

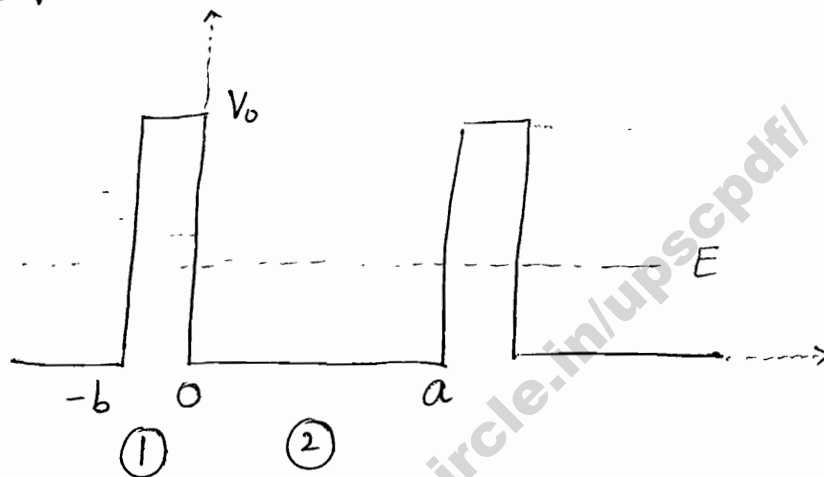

Writing eqn.

$$\frac{d^2\psi_1}{dx^2} + \frac{2m}{\hbar^2} (E - V_0) \psi_1 = 0 \quad -b < x < 0$$

$$\frac{d^2\psi_2}{dx^2} + \frac{2m}{\hbar^2} E \psi_2 = 0 \quad 0 < x < a$$

Using  $\alpha^2 = \frac{2mE}{\hbar^2}$ ,  $\beta^2 = \frac{2m(V_0 - E)}{\hbar^2}$ ,  $\psi_1 = e^{ikx} u_1(x)$   
 $\psi_2 = e^{ikx} u_2(x)$

$$\left[ \begin{array}{l} \alpha \Leftrightarrow k \\ \beta \Leftrightarrow \gamma \end{array} \right]$$

Hence, we get

$$\left( \frac{d^2 u_2}{dx^2} \right) + 2ik \left( \frac{du_2}{dx} \right) + (\alpha^2 - k^2) u_2 = 0 \quad 0 < x < a$$

$$\left( \frac{d^2 u_1}{dx^2} \right) + 2ik \left( \frac{du_1}{dx} \right) - (\beta^2 + k^2) u_1 = 0 \quad -b < x < 0$$

For simplification,  $V_0 \rightarrow \infty$   
 $b \rightarrow 0$

$V_0 b$  : finite, called Barrier strength

Hence, upon using Continuity & differential continuity, we get  
 (after further calculations)

$$P = \frac{mV_0 b}{\hbar^2} \left( \frac{mV_0 b}{\hbar^2 \alpha} \right) \sin(\alpha a) + \cos(\alpha a) = \cos(ka)$$

$$\Rightarrow P \left( \frac{\sin(\alpha a)}{\alpha a} \right) + \cos(\alpha a) = \cos(ka)$$

(Can also use  $P = \frac{mV_0 b}{\hbar^2}$ )

Only those values of  $(\alpha a)$  are allowed for which L.H.S. lies between  $-1$  and  $+1$ . From this the following conclusions are drawn:

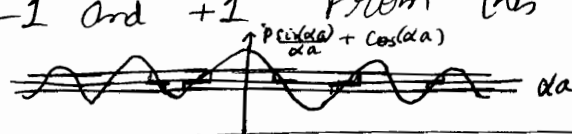

- 1) Energy spectrum consists of alternate regions of allowed energy bands and forbidden energy bands.
- 2) Width of bands increases with  $\alpha$  (or energy).

$\cos ka = \pm 1$  (for discontinuity)  $\Rightarrow ka = \pm n\pi$

$\Rightarrow$  Bands are discontinuous at  $k = \pm \frac{\pi}{a}, \pm \frac{2\pi}{a}, \pm \frac{3\pi}{a} \dots$

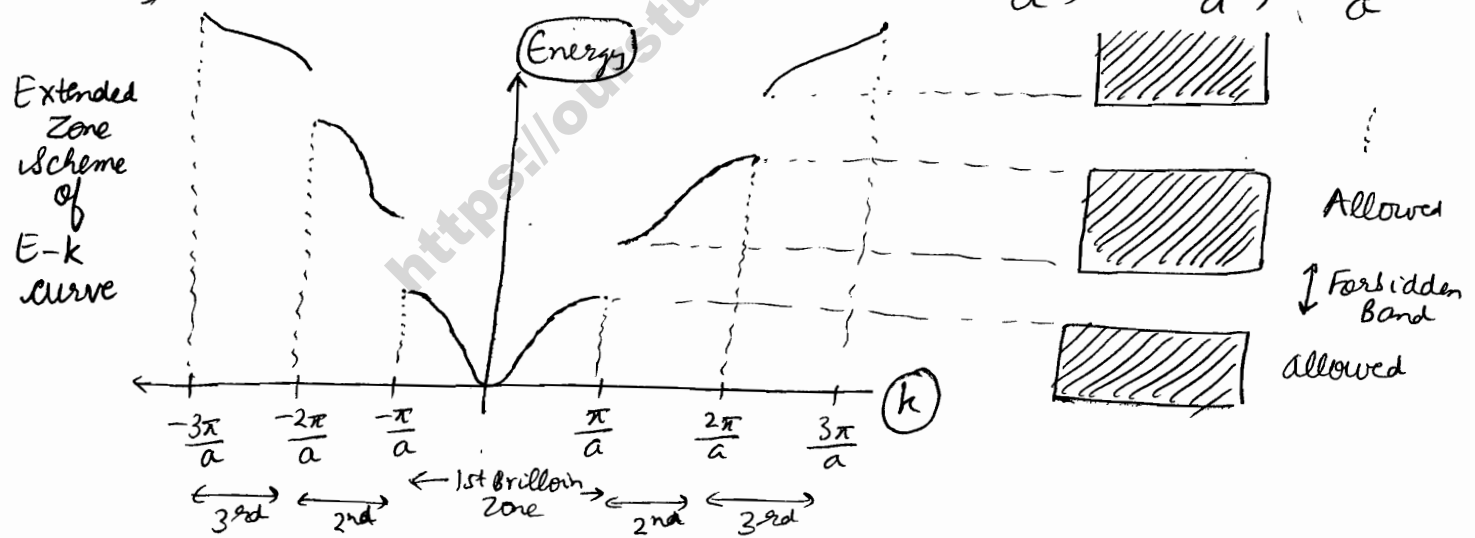

Note that these values of  $k$  define the boundaries of the Brillouin zones. The Bragg reflections at these boundaries result in discontinuities in  $E-k$  curve.

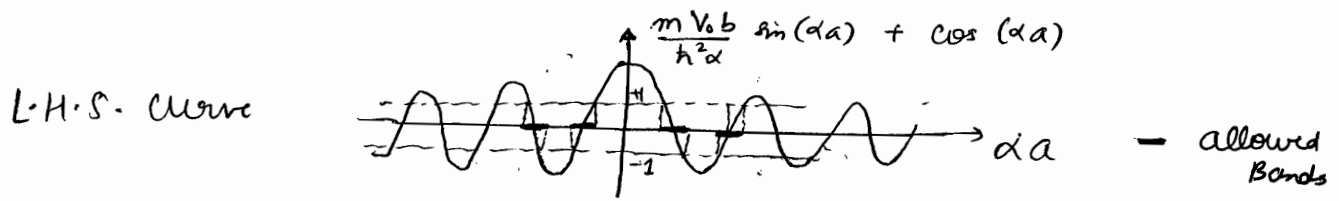

( $E=0$  कसे allowed है, in extended zone scheme)



The previous E-k curve is for intermediate Bound  
For loosely bound,  $V_0 b \rightarrow 0$

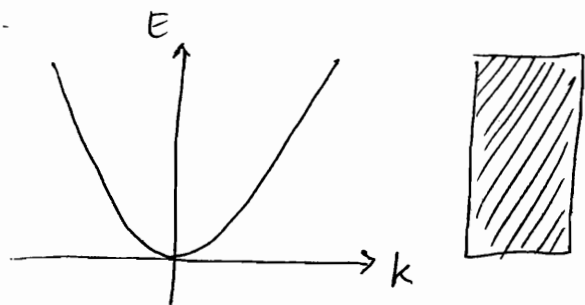

loosely bound  
Case

For tight bound,  $V_0 b \rightarrow \infty$

$$\Rightarrow \sin \alpha a = 0$$

$$\alpha a = n\pi$$

$$\Rightarrow E = \left( \frac{n^2 h^2}{8ma^2} \right) \quad (n=1, 2, 3, \dots)$$

i.e. independent of k

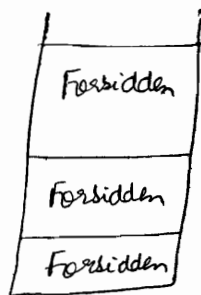
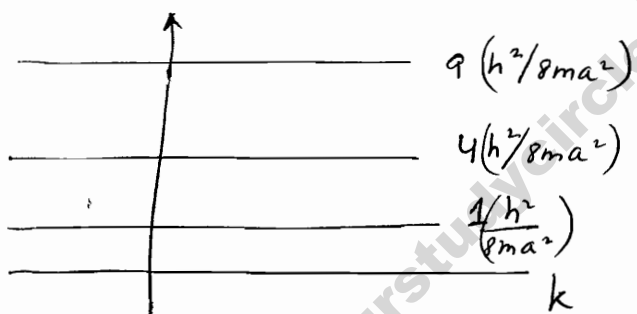

similar to 1-D  $\infty$  box

Explanation by Brillouin Zones

We know for diffraction  $2\vec{k} \cdot \vec{G} + G^2 = 0$

For one-dimension case,

Primitive lattice vector  $\vec{a}_1 = a \hat{x}$

$\Rightarrow$  Reciprocal lattice vector  $\vec{a}_1^* = \left( \frac{2\pi}{a} \right) \hat{x}$

$\Rightarrow$  Reciprocal lattice vector  $\vec{G} = n_x \vec{a}_1^* = \frac{2\pi n_x}{a} \hat{x}$

Let us write  $\vec{k} = k_x \hat{x} + k_y \hat{y} + k_z \hat{z}$

$$\Rightarrow 2\vec{k} \cdot \vec{G} + G^2 = 0 \Rightarrow 2 \cdot \frac{2\pi n_x}{a} k_x + \left( \frac{2\pi n_x}{a} \right)^2 = 0 \Rightarrow k_x = \left( \frac{n_x \pi}{a} \right)$$

## No. of wavefunctions in a band

For a crystal of length  $L$  & no. of primitive cells =  $N$ ,

$$\psi(x+L) = \psi(x)$$

$$\Rightarrow e^{ik(x+L)} u_k(x+L) = e^{ikx} u_k(x)$$

$$\Rightarrow e^{ikL} = 1$$

$$\Rightarrow \boxed{k = \left(\frac{2n\pi}{L}\right)} \quad n = \pm 1, \pm 2, \pm 3, \dots$$

$$\Rightarrow k = \pm \left(\frac{2\pi}{L}\right), \pm \left(\frac{4\pi}{L}\right), \pm \left(\frac{6\pi}{L}\right), \dots$$

$$\Rightarrow dk = \left(\frac{2\pi}{L}\right) dn \quad \Rightarrow dn = \left(\frac{L}{2\pi}\right) dk$$

$$\begin{aligned} \Rightarrow \text{Total no. of states} &= \int dn \\ &= \int_{-\frac{\pi}{a}}^{\frac{\pi}{a}} \cdot \frac{L}{2\pi} dk \\ &= \frac{L}{2\pi} \cdot \frac{2\pi}{a} \end{aligned}$$

$$\left( \text{assuming } b \rightarrow 0 \right) \quad = \left(\frac{L}{a}\right)$$
$$N = \frac{L}{a+b} \approx \left(\frac{L}{a}\right) \quad = N$$

But each state can occupy 2 electrons

$\rightarrow$  each band has a maximum  $2N$  electron states  
i.e. can accommodate  $2N$  electrons.

## Effective Mass

a particle moving with velocity  $v$  is equivalent to a wave packet moving with a group velocity  $v_g$

$$v = v_g = \left(\frac{d\omega}{dk}\right)$$

Also  $E = \hbar \omega \Rightarrow$

$$v = \frac{1}{\hbar} \left( \frac{dE}{dk} \right)$$

(11)

Considering the first Brillouin zone

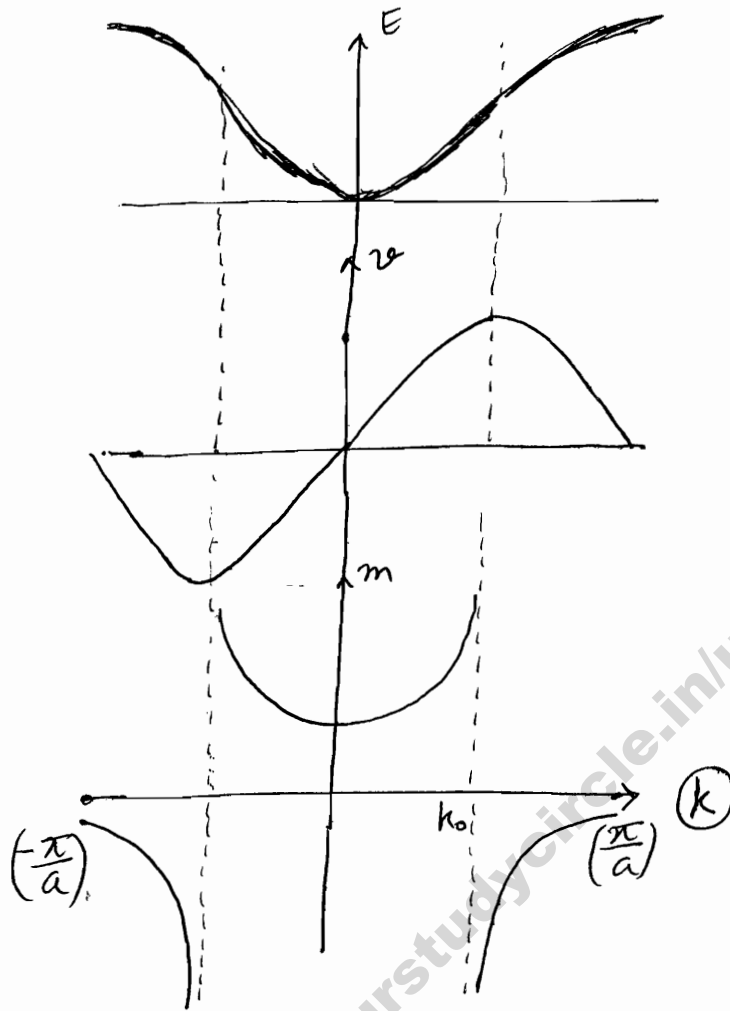

$k_0$ : inflexion point of  $E(k)$  curve

The mass of an electron in a crystal, in general, appears different from free  $e^-$  mass, and is referred to as  $m^*$ . We find expression for  $m^*$  from a semi-classical model.

Acceleration  $a = \left( \frac{dv}{dt} \right) = \frac{1}{\hbar} \left( \frac{d^2E}{dk^2} \right) \cdot \left( \frac{dk}{dt} \right)$

Let us consider electron to be placed in an electric field  $E_0$ , s.t. work done by electric field on the electron, at a particular  $k$ , will increase the energy by  $dE$

$$dE = e E_0 dx = e E_0 v dt = \frac{e E_0}{\hbar} \left( \frac{dE}{dk} \right) \cdot dt$$

$$\Rightarrow \left( \frac{dE}{dt} \right) = \frac{e E_0}{\hbar} \left( \frac{dE}{dk} \right)$$

$$\Rightarrow \left( \frac{dE}{dk} \right) \left( \frac{dk}{dt} \right) = \frac{e E_0}{\hbar} \left( \frac{dE}{dk} \right) \Rightarrow \left( \frac{dk}{dt} \right) = \frac{e E_0}{\hbar}$$

$$\Rightarrow m^* = \frac{F}{a} = \frac{eE_0}{\frac{1}{\hbar} \left( \frac{d^2E}{dk^2} \right) \left( \frac{dk}{dt} \right)} = \frac{eE_0}{\frac{1}{\hbar} \left( \frac{d^2E}{dk^2} \right) \frac{eE_0}{\hbar}} = \frac{\hbar^2}{\left( \frac{d^2E}{dk^2} \right)}$$

## Concept of negative mass

Effective mass, taking negative values can be understood by Bragg's reflection when  $k$  is close to  $\pm \left( \frac{\pi}{a} \right)$ . Due to Bragg's reflection, a force applied in one direction will lead to gain of momentum in the opposite direction, resulting in negative effective mass.

For alkali metals, partially filled band implies conduction taking place mainly through electrons. However in crystals for which energy band is nearly full, except for a few electron vacancies at top of band, these negative charge & negative mass vacancies may be considered as positive charge & positive mass particles called HOLES, which act as  $\oplus$ ve charged carriers to produce conduction.

## Effective no. of free electrons

[ Negative charge, negative mass  $\nabla$  (state)  $\nabla$  Vacancy = hole  
equivalent to positron in fermi model ]

$$\text{let } f_k = \frac{m}{m^*} = \frac{m}{\hbar^2} \left( \frac{d^2E}{dk^2} \right)$$

Measure of extent to which electron behaves as a free electron  
 $f_k = 1 \Rightarrow e^-$  behaves totally as free electron

If  $f_k < 1 \Rightarrow e^-$  behaves as a heavy particle: less mobility & therefore less conduction.  
 let energy band be filled upto  $k = k_1$ .

We know  $dn = \frac{L}{\pi} dk$

$$N_{\text{eff}} = \int_{-k_1}^{k_1} f_k dn = \frac{2mL}{\pi \hbar^2} \int_0^{k_1} \left( \frac{d^2E}{dk^2} \right) dk$$

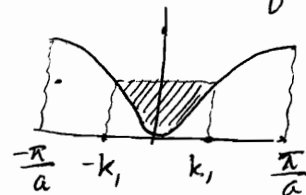

$$N_{\text{eff}} = \frac{2mL}{\pi \hbar^2} \left( \frac{dE}{dk} \right)_{k=k_0}$$

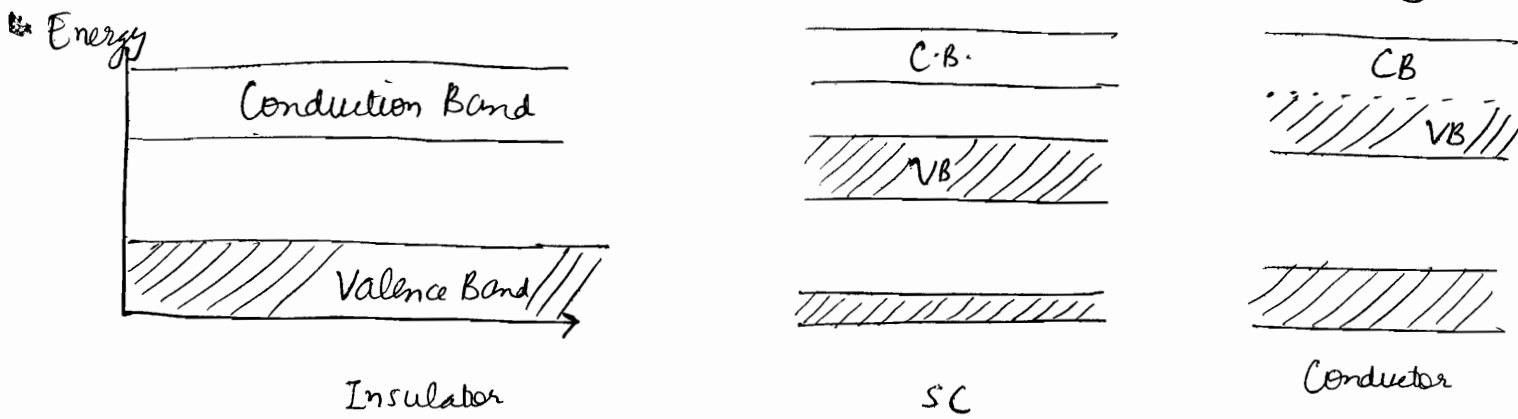

@  $T = 0\text{K}$

- For completely filled band,  $\left(\frac{dE}{dk}\right) = 0 \Rightarrow N_{\text{eff}} = 0 \Rightarrow \text{insulator}$
- For maximum  $N_{\text{eff}}$ , band should be filled upto inflexion point  
 ⇒ Partly filled band has metallic character

## Magnetism in Solids

### Diamagnetism

- ① Magnetism, in general, in solids is due to
  - spin of electrons
  - orbital motion of electrons
  - spin of nuclei
- ② Weak effect; in solids which do not contain permanent magnetic moment; due to orbital motion of electrons; directed opposite to applied magnetic field.
- ③ Induced current due to change of electron motion, according to Lenz's law
- ④ Diamagnetism exists in all materials but is usually suppressed due to presence of stronger effects like paramagnetism, ferromagnetism etc.
- ⑤ Manifested by small & negative value of  $\chi$ .

# Langevin's Classical theory

Let electron revolve around nucleus in a circular orbit with frequency  $\omega_0$  (of radius  $\rho$ )

$$\Rightarrow m\omega_0^2 \rho = \frac{Ze^2}{4\pi\epsilon_0 \rho^2}$$

$$\Rightarrow \omega_0 = \sqrt{\frac{Ze^2}{4\pi\epsilon_0 m \rho^3}}$$

Now an external magnetic field  $\vec{B}$  is applied.

$$\vec{F}' = e(\vec{v} \times \vec{B}) = e\rho\omega B$$

$$\Rightarrow \text{Net force} = \vec{F}_{\text{nucleus}} + \vec{F}' = m\omega^2 \rho$$

$$\Rightarrow m\omega^2 \rho = \frac{Ze^2}{4\pi\epsilon_0 \rho^2} - e\rho\omega B$$

$$- \quad = m\omega_0^2 \rho - e\rho\omega B$$

$$\Rightarrow \omega^2 + \left(\frac{eB}{m}\right)\omega - \omega_0^2 = 0$$

$$\Rightarrow \boxed{\omega \approx \omega_0 - \frac{eB}{2m}}$$

~~Langevin's~~ Larmor Theorem

(Considering  $\omega_0 \gg \frac{eB}{2m}$ )

$$\Rightarrow \Delta\gamma = \frac{1}{2\pi} \frac{eB}{2m}$$

Due to change in frequency, current is altered in the current loop

Additional Current =  $e \times$  additional frequency in 1 loop

$$= -\left(\frac{e^2 B}{4\pi m}\right)$$

$$\Rightarrow \text{Magnetic Moment} = -\left(\frac{e^2 B \rho^2}{4m}\right)$$

For  $Z$  electrons, total induced magnetic moment (13)

$$\mu_T = - \frac{Ze^2 B}{4m} \langle p^2 \rangle \quad \left( \begin{array}{l} Z \text{ is multiple} \\ \text{of } \frac{3\pi^2 R^2}{4\pi} \\ \langle p^2 \rangle \text{ is average} \end{array} \right)$$

now note that if field along  $z$ -axis, then

$$\langle p^2 \rangle = \langle x^2 \rangle + \langle y^2 \rangle$$

= mean of squares of  $\perp$  distances from axis of the field

Also  $\langle r^2 \rangle = \langle x^2 \rangle + \langle y^2 \rangle + \langle z^2 \rangle$   
 = mean square distance of electron from nucleus.

For spherical dist<sup>n</sup>,  $\langle x^2 \rangle = \langle y^2 \rangle = \langle z^2 \rangle$   
 of charge

$$\Rightarrow \mu_T = - \frac{Ze^2 B}{4m} \cdot \frac{2}{3} \langle r^2 \rangle = - \frac{Ze^2 B}{6m} \langle r^2 \rangle$$

For a solid containing  $N$  atoms per unit volume.

$$\chi_{\text{dia}} = \frac{M}{H} = \frac{N \mu_T \mu_0}{B} = - \frac{N Z e^2 \mu_0}{6m} \langle r^2 \rangle$$

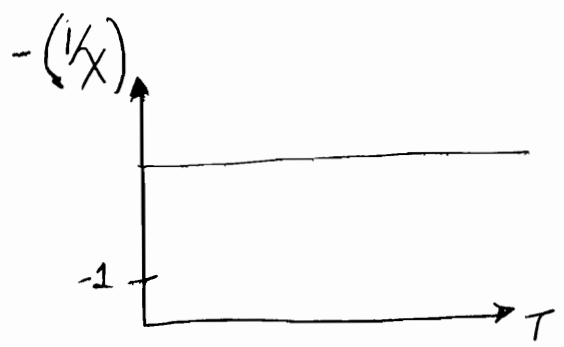

$\chi_{\text{dia}}$  is independent of temperature

Paramagnetism ( $O_2$ , metals, Unpaired electron atoms)

⊙ In those atoms, that have permanent magnetic dipole moment. In absence of magnetic field, moments are randomly oriented, but when  $\vec{B}_{\text{ext}}$  is applied, dipoles are oriented  $\parallel$  to field.

It leads to magnetization in the direction of field.

- ⊙  $\chi$  is small, positive & temperature dependent.
- ⊙ Observed paramagnetism in :
  - metals
  - atoms / molecules having odd number of electrons
  - $O_2$  molecule
  - rare earth & actinide elements

### Langmuir's Classical Theory

Consider a paramagnetic gas containing  $N$  atoms per unit volume, each having permanent magnetic moment  $\mu$ .

In absence of magnetic field, they are randomly oriented  
→ net moment = 0

When  $\vec{B}_{ext}$  is applied, dipoles orient themselves in the direction of the field to minimize their energy ( $E = -\vec{\mu} \cdot \vec{B}$ )  
But due to thermal energy, not exactly  $\parallel$ , but rather at an angle  $\theta$  with the direction of field.

$$\Rightarrow E = -\vec{\mu} \cdot \vec{B} = -\mu B \cos \theta$$

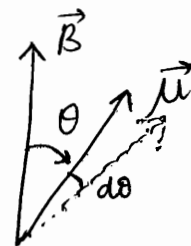

Now from Maxwell Boltzmann distribution,

no. of dipoles having orientation  $\theta \propto e^{\left(\frac{\mu B \cos \theta}{kT}\right)}$

No. of dipoles within solid angle  $d\omega$  lying between 2 hollow cones of semi angle  $\theta$  and  $\theta + d\theta$ , are

$$dn \propto e^{\left(\frac{\mu B \cos \theta}{kT}\right)} d\omega$$

$$= k e^{\left(\frac{\mu B \cos \theta}{kT}\right)} 2\pi \sin \theta d\theta$$

where  $k$  is a constant.



Each one contributes moment  $\mu \cos \theta$  to  $\vec{M}$ .

(14)

$$\Rightarrow M = \frac{\int \mu \cos \theta \, dn}{\int dn} = N \int \mu \cos \theta \, dn$$

$$= \frac{\mu N \int_0^\pi \sin \theta e^{\left(\frac{\mu B \cos \theta}{kT}\right)} \cos \theta \, d\theta}{\int_0^\pi \sin \theta e^{\left(\frac{\mu B \cos \theta}{kT}\right)} \, d\theta}$$

let  $\left(\frac{\mu B}{kT}\right) = \lambda$

N: NO. of dipoles per unit volume.

$$\Rightarrow M = \mu N f(\lambda)$$

$f(\lambda)$ : Langevin function

For small  $\lambda$ ,  $f(\lambda) \approx \left(\frac{\lambda}{3}\right) = \left(\frac{\mu B}{3kT}\right)$

$$\Rightarrow M = \left(\frac{\mu^2 N B}{3kT}\right)$$

$$\chi_{para} = \frac{\mu_0 M}{B} = \left(\frac{\mu_0 \mu^2 N}{3kT}\right) = \left(\frac{C}{T}\right)$$

C: Curie's constant  
 $= \left(\frac{\mu_0 N \mu^2}{3k}\right)$

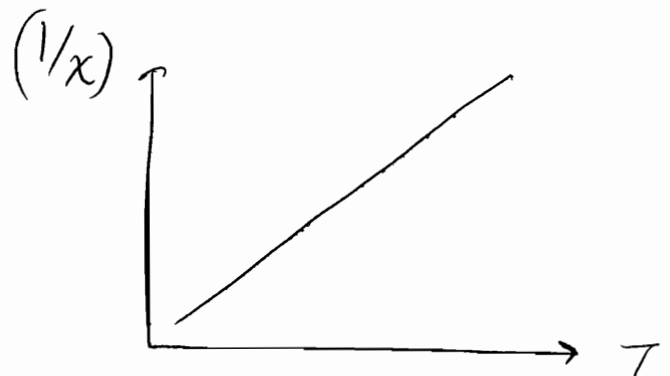
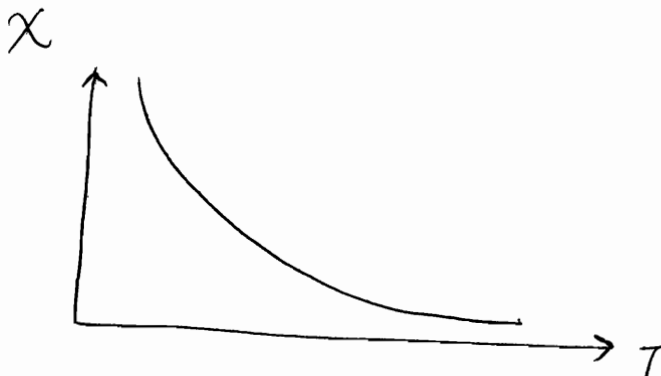

For large  $\lambda$

(large  $\lambda \Rightarrow$  small  $T \Rightarrow$  all dipoles get aligned)  
 $\Rightarrow M = \mu N$

$$f(\lambda) \approx 1$$

$$M = \mu N \Rightarrow \text{saturation magnetization}$$

## Ferromagnetism (Fe, Ni, Co)

- Also associated with permanent dipole moment, but here magnetic moments of adjacent atoms are aligned in a particular direction even in the absence of applied magnetic field.

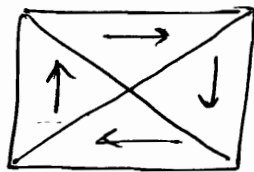

This magnetization that exists even in the absence of applied magnetic field is called SPONTANEOUS MAGNETIZATION. It exists below a critical temperature  $T_c$ , called CURIE TEMPERATURE.

- Above Curie Temperature, thermal effects offset the spin alignment and ferromagnetic substance becomes paramagnetic.
- $\chi$  is large and positive, varies with temperature as well as applied field (hysteresis loop)

## Weiss theory of Ferromagnetism

### 2 hypothesis

- Ferromagnetic material contains a no. of small regions called domains which are spontaneously magnetized. Magnitude of spontaneous magnetization of specimen as a whole is given by vector sum of magnetic moment of individual domains.

② Spontaneous magnetization of each domain is due to ⑮ presence of an exchange field  $B_E$ , which tends to produce a parallel alignment of atomic dipoles. Field  $B_E$  is assumed to be proportional to the magnetization  $M$  of each domain.

$$B_E = \lambda M \quad : \text{Weiss Field / Exchange Field / Molecular Field}$$

$\lambda$ : Weiss Field Constant (independent of temperature)

$B_E$  is quite strong as compared to applied field ( $\approx 1 \text{ T}$ ) ( $\approx 1000 \text{ T}$ )

From quantum theory, we can derive 2 curves

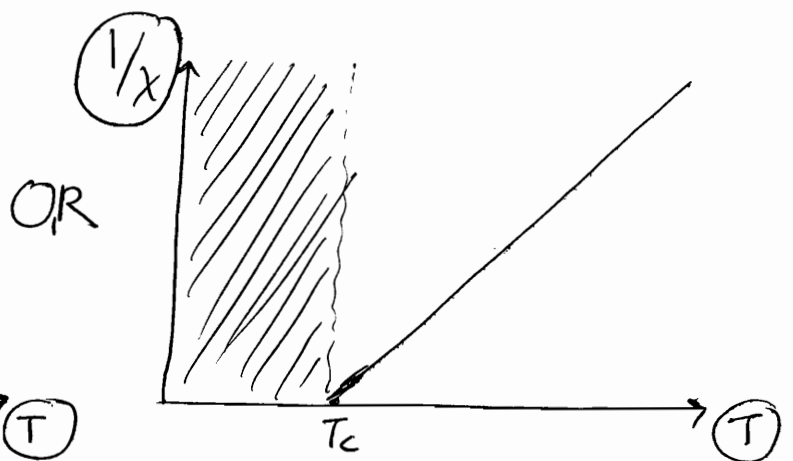
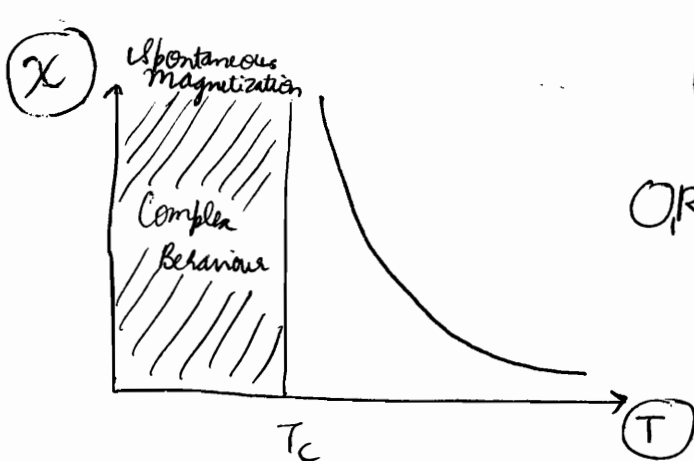
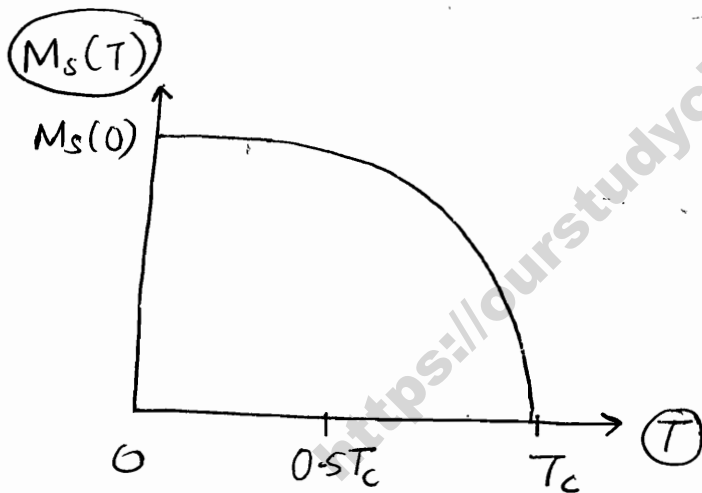

$$\chi = \left( \frac{C}{T-T_c} \right) \quad : \text{Curie-Weiss law}$$

Origin of Weiss Field was explained by Heisenberg who proposed the field to be a consequence of quantum mechanical exchange interaction between atoms. Interaction arises due

to Pauli's exclusion principle (any change in relative orientation of 2 spins would disturb spatial dist<sup>n</sup> of charge, thus producing interaction between two atoms)

Hence, the exchange interactions between neighbouring dipoles in a ferromagnetic substance generates an internal exchange field  $B_E$ , which aligns them in a particular direction.

### Domain Structure

According to Neel, domain structure is such that there is minimization of total energy (magnetic field energy + anisotropic energy + domain wall energy) [MAD]

Magnetization produced in ferromagnetic material is due to

- 1) Growth in size of  $\parallel$  domains at expense of antiparallel domains w.r.t. applied  $\vec{B}$
- 2) Rotation of direction of magnetization, along field direction

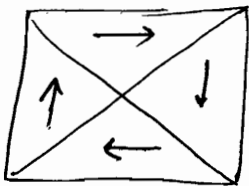

Unmagnetized specimen

$H_{\text{applied}} \uparrow$

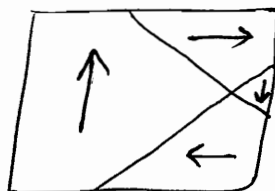

magnetization by domain growth

$H_{\text{applied}} \uparrow$

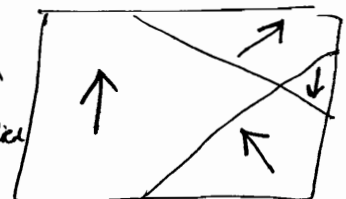

magnetization by domain rotation

⊙ Apart from them we have

### Antiferromagnetism (MnO)

- ⊙ Adjacent Moments are equal & opposite to each other
- ⇒ Complete cancellation of moments.

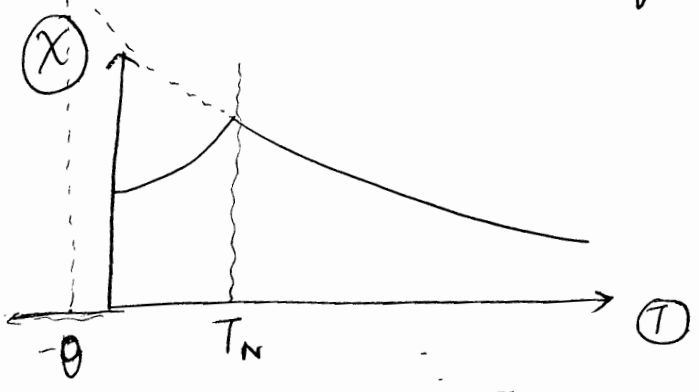

$$\chi = \left( \frac{C}{T + \theta} \right) \text{ for } T \gg T_N$$

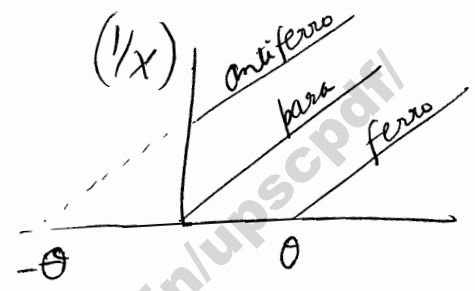

### Ferrimagnetism ( $Fe_3O_4 = FeO \cdot Fe_2O_3$ ) (ferrites)

- ⊙ Identical to antiferromagnetism except magnetization is not completely cancelled.
- ⊙ resembles ferromagnetism as
  - both possess spontaneous magnetization
  - both exhibit hysteresis

# Superconductivity

- ⊙ An electromagnet made up of a superconductor can function for years together even after removal of supply voltage. However, due to requirement of very low temp., it was not feasible to manufacture such devices.
- ⊙ Initial aim was to have a superconductor with transition temperature equal to or higher than 77k, the liquid N<sub>2</sub> temperature. With discovery of Ceramic superconductors ( $T_c \approx 90k$ ), eg  $YBa_2Cu_3O_7$  and Thallium superconductors ( $T_c \approx 125k$ ), now the aim is to find superconductors at room temperature.

## Meissner Effect (Explained by London equations)

- ⊙ Flux exclusion is independent of order of events. As well as reversible

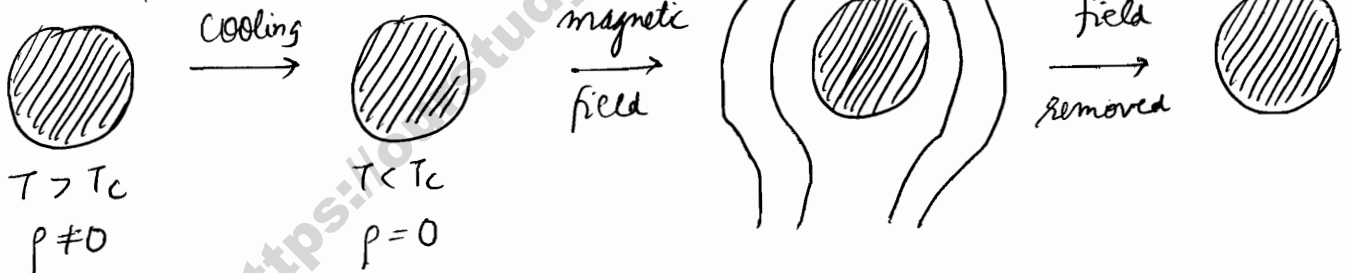

$\rho$ : resistivity

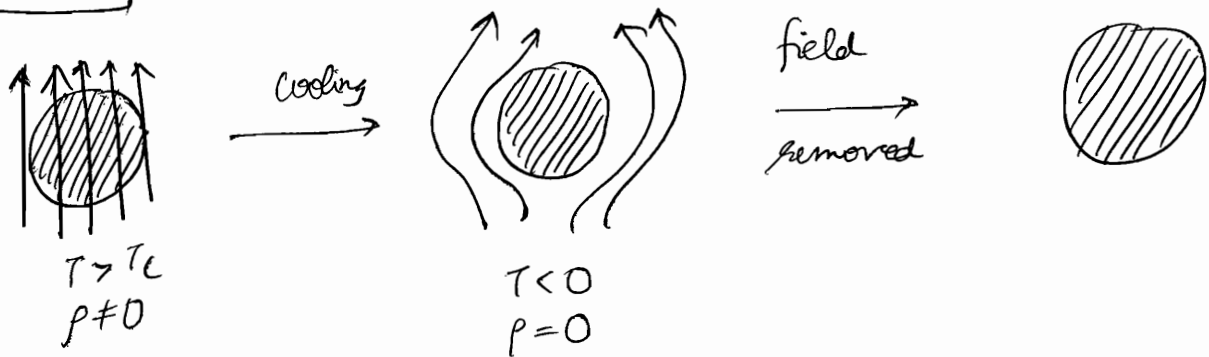

- ⊙ difference between perfect conductor ( $\rho = 0$ ) & Superconductor ( $\rho = 0$ )

For conductor,  $\rho = 0 \Rightarrow$  Ohm's law  $E = \rho J = 0$   
 i.e. no electric field inside perfect conductor

From Maxwell eqn,

$$\vec{\nabla} \times \vec{E} = -\frac{\partial \vec{B}}{\partial t}$$

$$\Rightarrow B = \text{const (and not zero)}$$

i.e. When conductor is cooled in the magnetic field until its resistance becomes 0 (becomes perfect conductor), the magnetic field in the material gets frozen in. & cannot change irrespective of applied field.

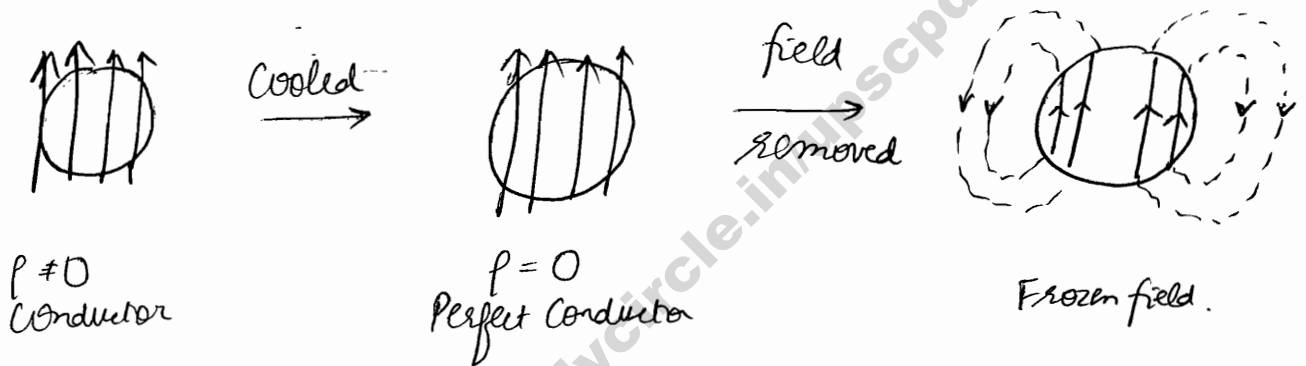

### Penetration Depth

Consider a superconductor with a plane surface, with magnetic field  $H_e$  acting parallel to surface. From Ampere's law,

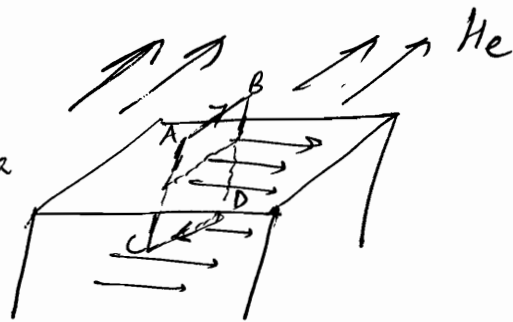

$$H_e (AB) = I_{enc}$$

(Note that  $H_{inside} = 0$  due to Meissner)

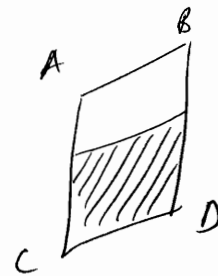

$I_{enc}$  or surface current per unit length =  $H_e$ . This surface current produces a magnetization  $\vec{M}$  which exactly cancels  $\vec{H}_e$  inside superconductor. Due to 0 resistivity, this current will remain almost constant indefinitely. Such currents are known as supercurrents.

keeping AB constant,  $I_{enc}$  remains same.

now if width AC of the loop is reduced, current remain unchanged  $\Rightarrow$  current density or  $\vec{J}$  increases. (Remember that there is no perfect surface current). For zero loop area current density approaches  $\infty$ , which is not possible physically.  $\Rightarrow$  supercurrent cannot become absolute zero as one move from surface to interior. This is possible only if applied magnetic field penetrates the superconductor up to a small thickness near the surface.

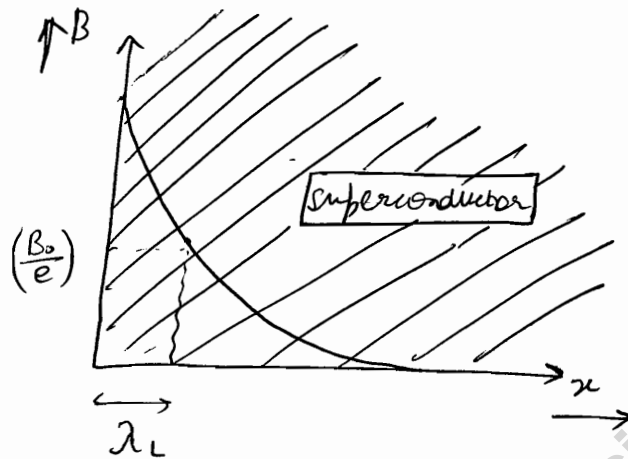

$\lambda_L$ : characteristic length  
or  
London penetration depth  
 $\approx 10^3 \text{ \AA}$

Experimentally,  $H_c(x) = H_c(0) e^{-\left(\frac{x}{\lambda_L}\right)}$   
(derived from London equations)

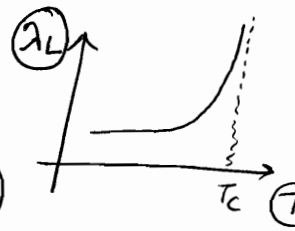

### Critical field

superconducting stage is stable only in some definite ranges of Temperature & Magnetic Field.

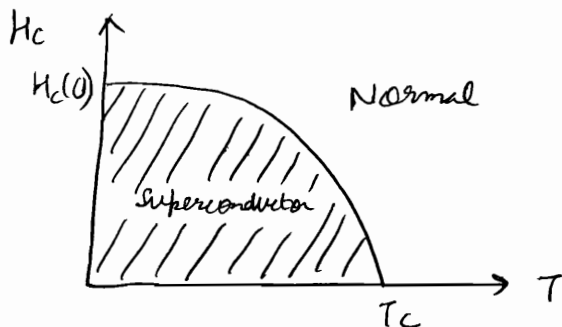

$$H_c(T) = H_c(0) \left[ 1 - \left( \frac{T}{T_c} \right)^2 \right]$$

### Type 1 and Type 2

Classification depending on behaviour in external magnetic field i.e. how strictly they follow Meissner effect



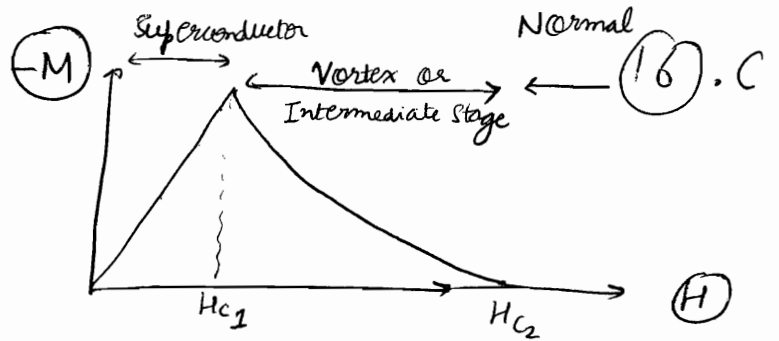
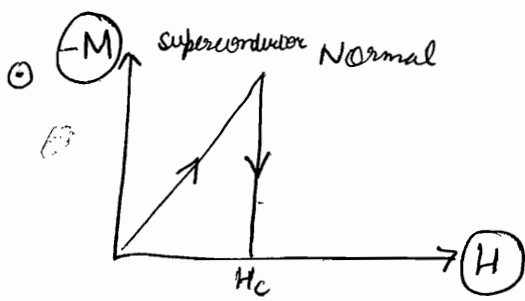

- Type 1
- (Pb)
- soft superconductors
- due to very low  $H_c$ , very limited applications

- Type 2
- Pb-Bi Alloy
- Hard superconductor
- Practical applications
- After  $H_{c1}$ , flux begins to penetrate the specimen & for  $H = H_{c2}$ , flux penetrates completely

### Entropy

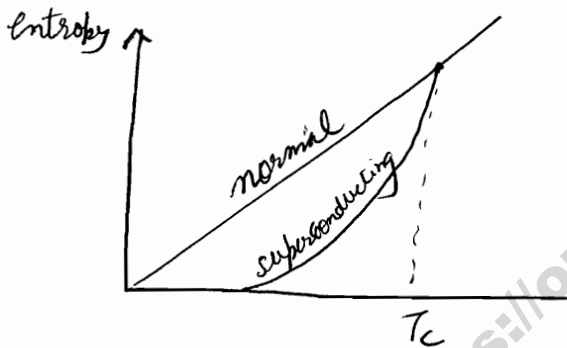

o  $P-T$  curve depends on the process like PV curve.  $y = mx$  given adjacent is assumed for a process.

- marked decrease in entropy in superconducting stage.
- electronic structure is mainly affected during superconducting transition.

→ some or all the thermally excited electrons in the normal state are ordered in the superconducting stage. Such an order may extend up to a distance of the order of  $10^{-6}m$  in Type 1 superconductors. This range is called Coherence length ( $\xi_0$ )

[ This helps to give another definition of type 1 & type 2 superconductors:  
 (I) :  $(\frac{\lambda_L}{\xi_0}) < \frac{1}{\sqrt{2}}$       (II) :  $(\frac{\lambda_L}{\xi_0}) > \frac{1}{\sqrt{2}}$  ]

Isotope Effect (मौटे आदमी को superconducting बनाना बहुत मुश्किल होता है)

$$T_c \propto \frac{1}{\sqrt{M}}$$

M: isotopic mass  
 $T_c$ : transition temp.

## Flux Quantization

$$\begin{aligned}\Phi &= n \left( \frac{h}{2e} \right) \\ &= n \text{ fluxoid}\end{aligned}$$

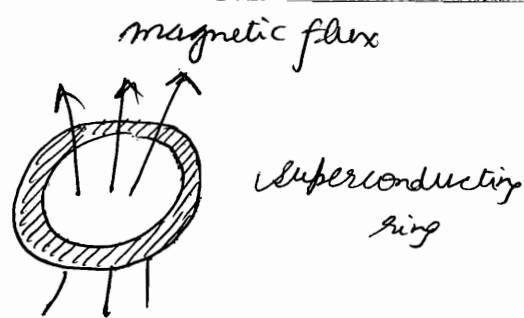

where 1 fluxoid =  $\frac{h}{2e} = 2.07 \times 10^{-15}$  Weber

## 3 Josephson Effects

### a) d.c. Josephson Effect

due to tunnelling of superconducting electrons through a very thin insulator (1-5 nm) sandwiched between two superconductors, d.c. current flows across the junction even when no voltage applied.

### b) a.c. Josephson Effect

When d.c. voltage  $V$  applied across junction, a.c. current of r.f. flows.

$$f = \left( \frac{2e}{h} \right) V$$

For  $1 \mu\text{V}$ ,  $f = 483.6 \text{ MHz}$

<u>units</u>
$V = \left( \frac{d\Phi}{dt} \right)$
$f = \frac{V}{\Phi} = \frac{V}{\left( \frac{h}{2e} \right)}$

### c) Quantum Interference

If a constant magnetic field is applied through a superconducting circuit containing 2 junctions, the maximum supercurrent shows interference effects depending on intensity of magnetic field.

Device used to show quantum interference is called SQUID.

16. D

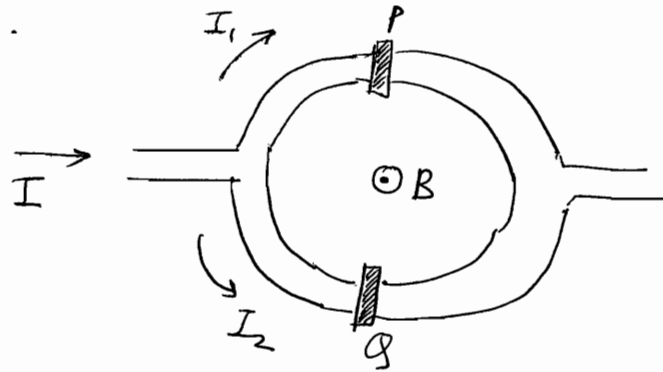

अरे भय I const  
 शोई एी ई... Resistance  
 of superconductor can  
 vary...  $\Rightarrow$  I can vary.  
 Now with change in  
 flux, resistance varies  
 $\Rightarrow$  I varies, showing  
 maxima at certain B.

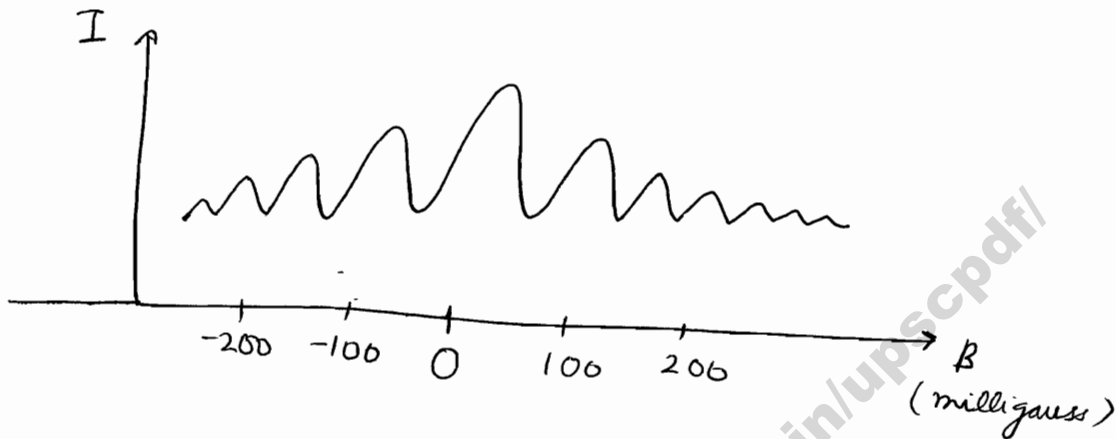

- Since current is sensitive to small changes in magnetic field, SQUID can be used as a very sensitive galvanometer.
- Superconductor is characterized by a single wave function. Flow of supercurrent takes place between any 2 points where the wave function has different phases. Change in phase can also be brought about by applied electric & magnetic fields. States having different phases can be superimposed in SQUIDS.

### BCS Theory

- Electron-Phonon-Electron interaction is the basis of formation of a Cooper pair which results in superconduction.
- When an electron moves through a crystal, it produces lattice distortion & sets heavier ions into slow forced oscillations. Since the electron moves very fast, it leaves the region much before oscillations could die off. Meanwhile, if

Another electron happens to pass through this distorted region, it experiences an attractive force. This attraction lowers the energy of the electron, forming Cooper Pair.

(Note that repulsive force between electrons is small since Coulomb force is instantaneous while attraction mediated by lattice distortion is highly retarded in time)

- Smaller the mass of the ion, larger is the energy of the phonons emitted & hence larger should be transition temperature. Same conclusion is drawn from isotope effect. The isotope effect suggested that superconductivity is related to ions too  $\Rightarrow$  foundation for BCS theory.

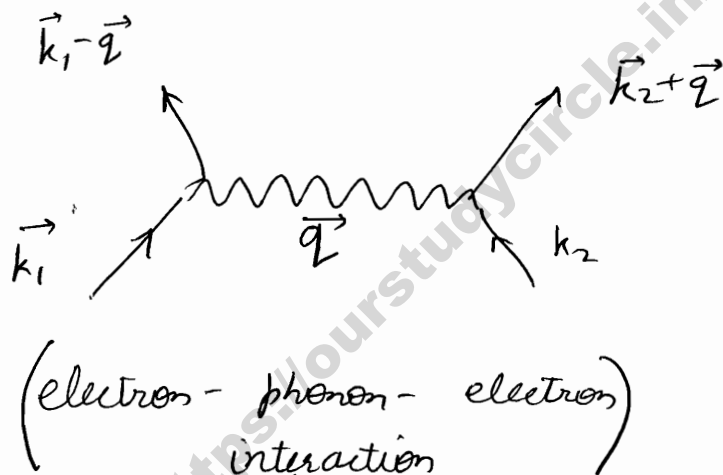

$\vec{k}_1, \vec{k}_2$  : 2 electrons  
 $\vec{q}$  : lattice distortion or phonon production

### Low Temperature Phenomenon

Binding Energy of Cooper Pair, called energy gap  $E_g \approx 10^{-3} \text{ eV}$

Hence temperature  $\approx \frac{10^{-3} \text{ eV}}{k} \approx 10 \text{ K}$ . Above that Cooper pair will be broken.

### Superconductivity due to Cooper Pair

Electron in a Cooper pair have opposite spin  $\Rightarrow$  Total spin = 0  
 $\Rightarrow$  Bosons i.e. any number of them can exist in same quantum state at the same time. A single wave function represents this system where total energy is less than that of system of same no. of 'e' with fermi-energy distribution.

Therefore, a current in a superconductor involves all the Cooper pairs acting as a single unit. To alter such a current, huge amount of energy is required (as lattice scattering is not enough, as in normal conductors)  
⇒ Current persists indefinitely.

### Critical field

- As magnetic field applied is increased, energy of Cooper pair increases (b'coz they exclude the field from interior of superconductor for Meissner effect). Beyond critical value, Cooper pair is dissociated.

### Meissner Effect

- Following Lenz's law, Cooper pairs move without any resistance & adjust their motion to produce a magnetic field opposite to applied field.

<https://ourstudycircle.in/upscpdf/>

(2) Electrical Properties  
Conductivity  $\sigma$   
Permittivity  $\epsilon_r \epsilon_0$   
Susceptibility  $\chi_e$   
Resistivity  $\rho$

(3) Thermal Properties  $C_p, C_v$   
(Einstein, Debye's, Dulong)

(4) Optical Properties refractive index ( $n$ )

(5) Superconductivity  
Meissner Effect  
Josephson Effect  
High Temperature Superconductivity

Superconductivity  
(Kamerlingh Onnes)  
1911 k. Onnes

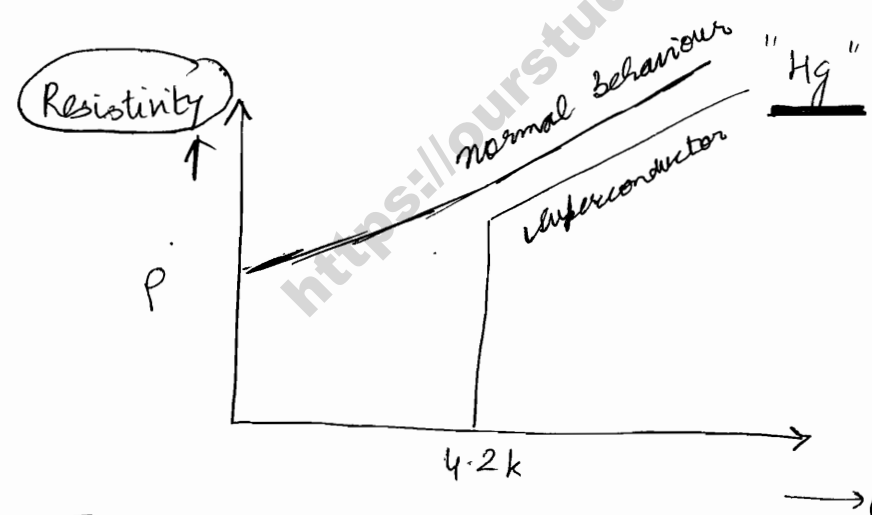

→ It was then observed for other materials also  
→ Till 1957, there was no theory to explain it.

Joseph Bardeen gave quantum theory to explain this.

Its called BCS theory or Bardeen, Cooper & Shriver Theory

It offers quantum mechanical explanation for superconductivity

→ There are multiple properties but we are interested only in few properties.

✓ In superconductor, current has been seen to flow for years. Some application of superconductors include:

- ✓ ① storage element in memory of computer
- ✓ ② Design of Maglevs
- ✓ ③ Design of very sensitive Magnetometers  $\approx 10^{-11}$  Tesla measurement.

### ① Critical Magnetic Field

✓ By applying magnetic field, superconductivity can be destroyed.

$B_c(T)$  = Critical Magnetic field at Temp "T" to destroy superconductivity

$B_c(0)$  = critical magnetic field at Temp 0K to destroy superconductivity

$$B_c(T) = B_c(0) \left[ 1 - \left( \frac{T}{T_c} \right)^2 \right]$$

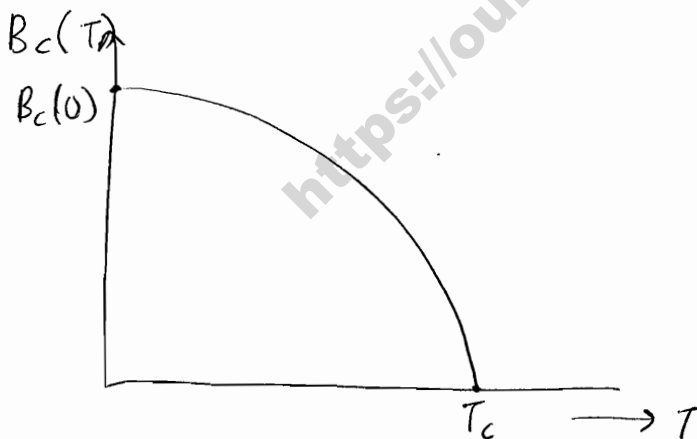

Parabolic Curve

→ इसमें B ज्यादा है, इसलिए superconductor के grains की alignment ही change कर देगा!!

### ② Meissner Effect

✓ Whenever specimens of superconducting materials in cooled down to lower temperatures, Magnetic Field inside the superconducting material is removed

ie. for  $T < T_c$ ,  $B_{\text{inside}} = 0$



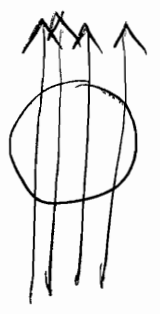

T > Tc

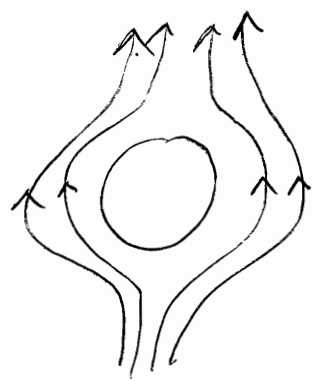

T < Tc

★ Meissner effect  
important diagram

Magnetic field lines are "oozed out" of superconducting material below T = Tc

We know,

$$\vec{B} = \mu_0 (\vec{H} + \vec{M})$$

Now  $\vec{B} = 0$  below  $T_c$

$$\Rightarrow \boxed{\frac{M}{H} = -1}$$

$$\text{or } \boxed{\chi = -1}$$

$\frac{M}{H}$  is called Magnetic susceptibility  $\chi$

(a dimensionless quantity)

usually  $\chi \approx 10^{-6}, 10^{-7}$  but here  $\chi$  is a large negative quantity.

[ Materials are classified on basis of susceptibility as Paramagnetic, Diamagnetic, Ferromagnetic. ]

if  $\chi = -10^{-7}$  to  $-10^{-6}$  : dipoles are aligned opposite to applied field.  
They are Diamagnetic Material

$\chi = 10^{-6}$  to  $10^{-7}$  : dipoles are aligned parallel to applied field  
They are Paramagnetic Material

$\chi$  : large  $\oplus$ ve : Ferromagnetic

$\chi = -1 \Rightarrow$  Perfect Diamagnetic

This property of superconductivity is exhibited as Meissner effect.

On the basis of Meissner Effects, we have 2 superconductor types:

1) **Type I superconductor**

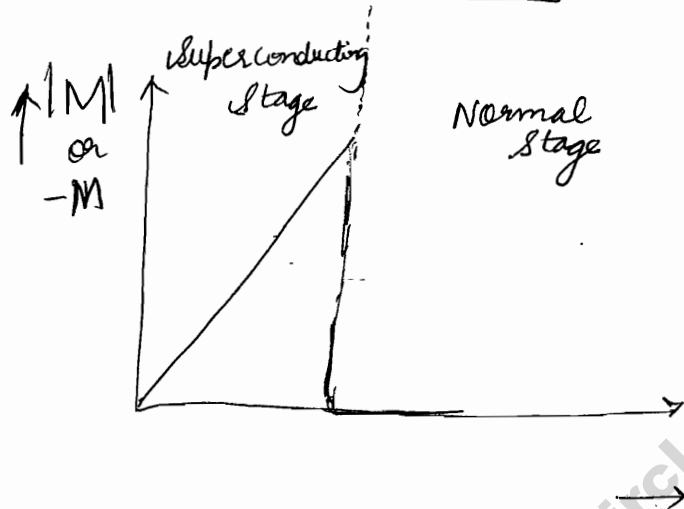

$$\left(\frac{M}{H}\right) = -1$$

eg. Lead (Pb)

$B_{\text{inside}} = 0$

**suddenly drops**

2) **Type II superconductor**

some amount of Magnetic Field will remain.

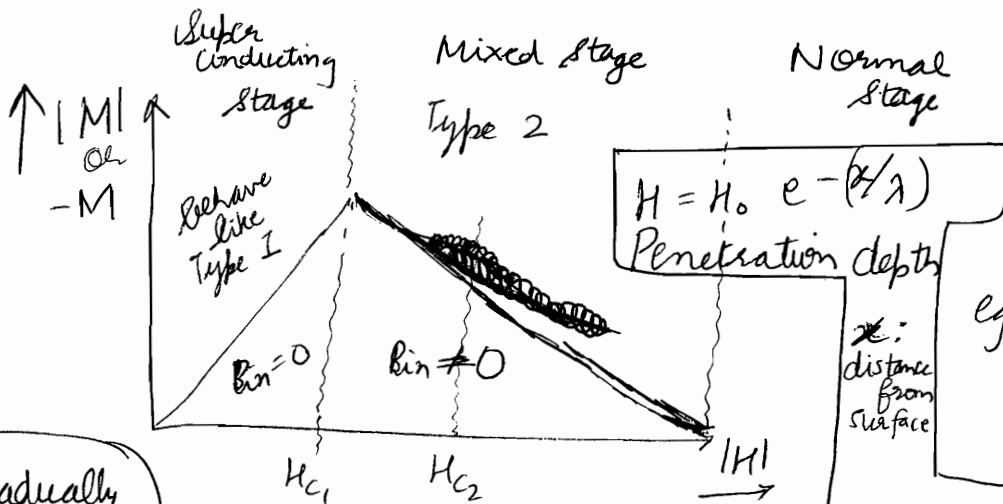

$$H = H_0 e^{-x/\lambda}$$

Penetration depth

$x$ : distance from surface

eg. Pb-In Alloy (Lead-Indium)

**gradually drops**

$$H_{c2} = H_c e^{-1} \quad \text{at } x = \lambda$$

$\lambda$ : Penetration depth

There are two parameters demarcating Type II superconductors

- ① Penetration Depth :  $\lambda$
- ② Coherence length :  $\xi_0$

$k = \left(\frac{\lambda}{\xi_0}\right)$  determines whether material is Type I or Type II

$k < \frac{1}{\sqrt{2}}$  Type I Material

\*  $\lambda \approx 0 \Rightarrow k$  very small

$k > \frac{1}{\sqrt{2}}$  Type II Material

B.C.S. Theory will successfully explain whole Meissner Effect.

### ③ Josephson Effect or Josephson Junction

Junction is made out of two superconductors (identical) with a very thin insulating layer in between, typically a Metal Oxide (sandwiched)

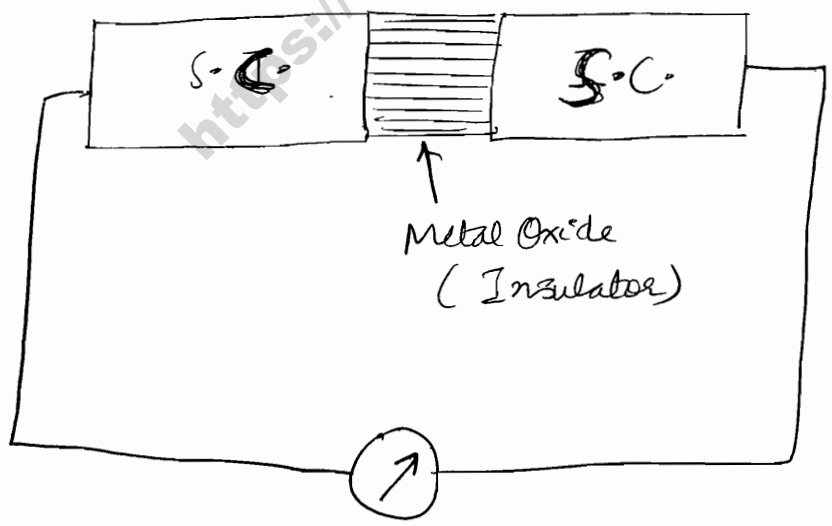

We observe Direct Current without application of any potential. This is D.C. Josephson Effect. Note that no  $\vec{E}$  or  $\vec{B}$  is applied, yet D.C. is created.

We also have A.C. Josephson Effect if a source of Electric field, a battery is applied.

# AC Josephson Effect

$$\checkmark \quad \hbar \omega = 2eV$$

( $2e$  charge due to Cooper pair)

$$\Rightarrow \boxed{\omega = \frac{2eV}{\hbar}}$$

A-C. Josephson Effect

for  $V=0$ ,  $\omega=0 \Rightarrow$  D-C. Josephson Effect

$$\Rightarrow \boxed{\gamma = \frac{2eV}{\hbar}}$$

3 applications of Josephson effect

①

Measurement of very low potential differences ( $10^{-6}$  volts)

- For  $1 \mu V$ , we have

$$\begin{aligned} \gamma &= \frac{2 \times 1.6 \times 10^{-19} \times 1 \times 10^{-6}}{6.6 \times 10^{-34}} \text{ Hz} \\ &= \frac{3.2}{6.62} \times 10^9 \text{ Hz} \end{aligned}$$

$$\boxed{\gamma = 483.3 \text{ MHz}}$$

I cannot discriminate b/w  $1 \mu V$  and  $2 \mu V$  but I can differentiate  $\gamma = 483.3 \text{ MHz}$  and  $2\gamma$ . Hence very sensity device can be created.

② Most sensitive measurement of  $\left(\frac{\hbar}{e}\right)$  can be done  
 $\left(\frac{\hbar}{e}\right) = \left(\frac{2V}{\gamma}\right)$  (Now can ably, say,  $1V$ )

③ To device very sensitive Magnetic galvanometers. (5) (20)

or Magnetometers

$$(B = 10^{-11} \text{ Tesla})$$

or

$$(10^{-7} \text{ Gauss})$$

This is explained on basis of fourth Property: Quantization of Magnetic Flux.

Note that "c" को दूरी CGS units में आता है. Remove "c" in S.I. unit.

### ④ Quantization of Magnetic Flux

If we make a closed loop of superconducting material, magnetic flux will be quantized.

$$\oint \vec{B} \cdot \vec{A} = \Phi = n S \left( \frac{hc}{2e} \right) \quad S \in \mathbb{N} \quad (1, 2, 3, \dots)$$

due to Cooper Pairs, there will always be  $2e$

$$\frac{2e \Phi}{\hbar} = 2\pi n = 2\pi, 4\pi, 6\pi, \dots$$

~~This is consequence of London equations~~

Application

SQUIDS

Superconducting  
Quantum  
Interference  
Device

[ in order to make  
very sensitive  
magnetometers ]

Here we 2 Josephson junctions in parallel in order to form a ring i.e. closed loop. Hence quantized flux.

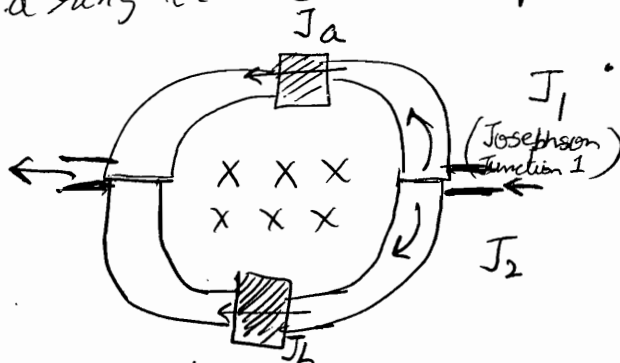

Now Apply external perpendicular field

$$\Phi = \left( \frac{hc}{2e} \right) n$$

Now A.C. is produced

Proof of Quantization (leave it)

$$J_1 = J_0 \sin \left[ \delta(0) - \frac{e\Phi}{\hbar} \right]$$

↑  
Current

↓  
dimensionally correct

(Quantization)  
वस ऐसे ही लिखना है !!

$$J_2 = J_0 \sin \left[ \delta(0) + \frac{e\Phi}{\hbar} \right]$$

In absence of magnetic field  
 $\delta_- = \delta(0)$   
i.e. the two phases are equal

$$J = J_1 + J_2 \quad (\text{interference})$$

But when magnetic field is applied

$$\Rightarrow J = \underbrace{J_0}_{\text{const.}} \cdot 2 \sin \delta(0) \cdot \underbrace{\cos \left( \frac{e\Phi}{\hbar} \right)}_{\text{function of } \Phi}$$

$$J_a = J_0 \sin(\delta_a)$$

$$J_b = J_0 \sin(\delta_b)$$

$$\delta_a = \delta_0 + \left( \frac{e\Phi}{\hbar} \right)$$

$$\delta_b = \delta_0 - \left( \frac{e\Phi}{\hbar} \right)$$

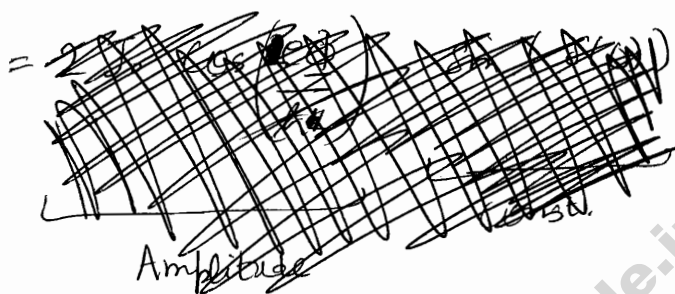

This is written because we know phase difference

$\theta_2 - \theta_1$ , around a closed circuit which encompasses a magnetic flux  $\Phi$  is

$$\theta_2 - \theta_1 = \left( \frac{2e}{\hbar} \right) \Phi$$

For maximum current,

$$\left| \cos \left( \frac{e\Phi}{\hbar} \right) \right| = 1$$

$$\Rightarrow \frac{e\Phi}{\hbar} = n\pi$$

$$\Rightarrow \frac{2e\Phi}{\hbar} = n$$

$$\Rightarrow \Phi = n \left( \frac{\hbar}{2e} \right) \quad \checkmark$$

Hence we have derived that flux in closed loop of superconductor is quantized, and current becomes maximum

1<sup>st</sup> maxima of current @  $\Phi = \left( \frac{\hbar}{2e} \right)$

2<sup>nd</sup> maxima of current @  $\Phi = \left( \frac{2\hbar}{2e} \right)$

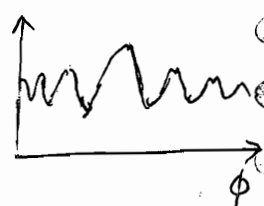

Hence observation of current maxima will give us the numerical values. (6) (21)

$$\phi = \frac{h c}{2e} \approx 10^{-7} \text{ weber} = 10 \text{ Maxwell}$$

(1 Maxwell =  $10^{-8}$  Wb)

Cross section Area of Squid  $\approx 1 \text{ cm}^2$

$$\Rightarrow B \approx 10^{-11} \text{ Tesla}$$

or  
 $10^{-7} \text{ gauss}$

1 gauss of  $B = 10^{-4} \text{ T}$

Use of squid :

- 1) very sensitive magnetometer
- 2) oil prospecting
- 3) to detect amount of iron in body.

### Proof of AC Josephson Effect

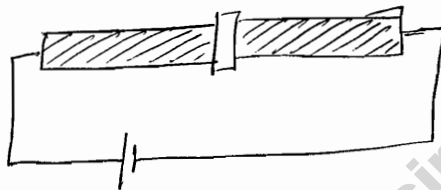

### BCS Theory

Resistivity is due to Coulomb repulsion of free electrons

If somehow I am able to change Coulomb repulsion into attractive interaction, then  $\rho$  is reduced.

Direct repulsion is replaced by indirect interaction via lattice (phonon) i.e.  $e^-$ -lattice interaction whereby  $2e^-$  form a closed pair

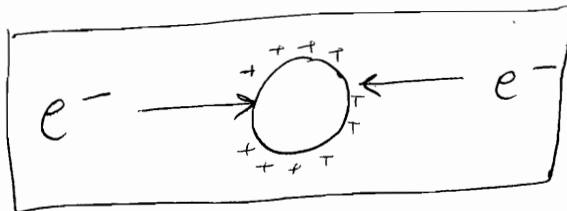

Interaction via lattice

$e^-$  collides or interacts with lattice. Energy of lattice is reduced. Other  $e^-$  is attracted

Now the individual  $e^-$  (fermions) becomes a pair of  $e^-$  (boson) with  $\vec{p}_1 = -\vec{p}_2$  and  $\vec{s}_1 = -\vec{s}_2$

This is called Cooper Pair of electrons.

Now superconductivity is flow of Cooper pairs of  $e^-$   
Each Cooper pair is a boson.

All the properties are explained via this model.

Here  $q = 2e$  : quantum of Cooper pair

BCS theory's explanation of Josephson effect

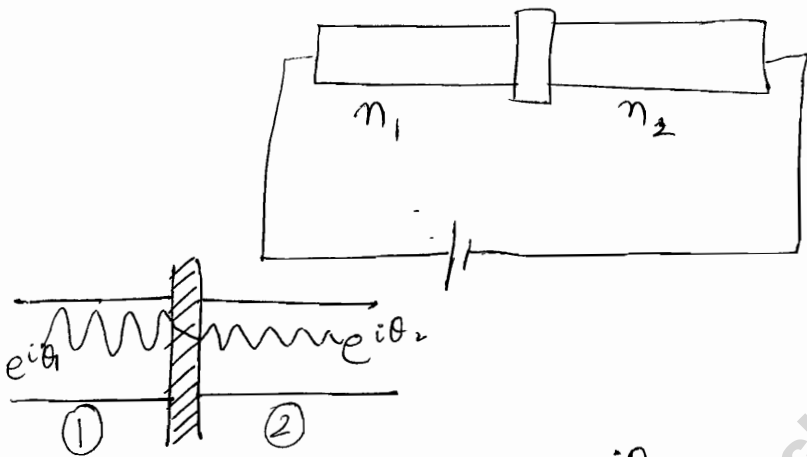

$n$  : Cooper Pair per Unit volume  
 if identical superconductor  
 $n_1 = n_2$

$$\psi_1 = \sqrt{n_1} e^{i\theta_1}$$

$$\psi_2 = \sqrt{n_2} e^{i\theta_2}$$

$$|\psi|^2 \propto n$$

$$\Rightarrow |\psi| \propto \sqrt{n}$$

Quantum solution

$$H\psi = E\psi$$

$$\Rightarrow H\psi = i\hbar \frac{\partial \psi}{\partial t}$$

Non stationary state phenomenon  
 $\Rightarrow$  time dependent

For region 1,

$$\left[ \begin{array}{l} \text{For region 1,} \\ i\hbar \frac{\partial \psi_1}{\partial t} = T\psi_2 - eV_0\psi_1 \\ \text{For region 2,} \\ i\hbar \frac{\partial \psi_2}{\partial t} = T\psi_1 + eV_0\psi_2 \end{array} \right.$$

T is the interaction having dimension  $\frac{2}{\partial T}$   
 "multiplicative operator"  
 (you can also have same sign of  $V_0$  as battery i.e.  $+eV_0\psi_1$  in 1st eqn)

For D.C. Josephson Effects, corresponding Equations are :

$$i\hbar \frac{\partial \psi_1}{\partial t} = T\psi_2$$

$$i\hbar \frac{\partial \psi_2}{\partial t} = T\psi_1$$



In (1) and (2), replacing  $\psi$  from definitions

(7) (22)

$$i \frac{1}{2\sqrt{n_1}} \frac{dn_1}{dt} e^{i\theta_1} + \sqrt{n_1} e^{i\theta_1} \left( \frac{d\theta_1}{dt} \right) = T\sqrt{n_2} e^{i(\theta_2 - \theta_1)} - \frac{eV_0 \sqrt{n_1}}{\hbar} e^{i\theta_1}$$

$$\Rightarrow \frac{1}{2\sqrt{n_1}} \frac{dn_1}{dt} i - \sqrt{n_1} \frac{d\theta_1}{dt} = -\frac{eV_0 \sqrt{n_1}}{\hbar} + T\sqrt{n_2} e^{i(\theta_2 - \theta_1)}$$

Put  $\theta_2 - \theta_1 = \delta$

$$\Rightarrow e^{i(\theta_2 - \theta_1)} = \cos \delta + i \sin \delta$$

Separating real & imaginary components,

$$\frac{1}{2\sqrt{n_1}} \frac{dn_1}{dt} = T\sqrt{n_2} \sin \delta \quad \text{--- (3) } \checkmark$$

$$\sqrt{n_1} \frac{d\theta_1}{dt} = \frac{eV_0 \sqrt{n_1}}{\hbar} - T\sqrt{n_2} \cos \delta \quad \text{--- (4)}$$

$$\frac{d\theta_1}{dt} = \frac{eV_0}{\hbar} - T\sqrt{\frac{n_2}{n_1}} \cos \delta \quad \text{--- (5) } \checkmark$$

Similarly (2) yields ( $V'$  will be  $-V$ ,  $\delta'$  will be  $-\delta$ )

$$\frac{1}{2\sqrt{n_2}} \frac{dn_2}{dt} = -T\sqrt{n_1} \sin \delta \quad \text{--- (6)}$$

$$\frac{d\theta_2}{dt} = -\frac{eV_0}{\hbar} - T\sqrt{\frac{n_2}{n_1}} \cos \delta \quad \text{--- (7)}$$

} replace  $V_0$  by  $-V_0$  and  $\delta$  by  $-\delta$

Now  $\left(\frac{dn_1}{dt}\right) = -\left(\frac{dn_2}{dt}\right)$  because current is same

Also can be seen from comparing (3) and (6)

subtracting (7) from (5)

$$\frac{d}{dt} (\theta_2 - \theta_1) = -\frac{2eV_0}{\hbar}$$

$$\boxed{\frac{d\delta}{dt} = -\left(\frac{2eV_0}{\hbar}\right)}$$

Remember  $\frac{d\phi}{dt} = \text{frequency}$

$\phi$ : Phase of function

$$\Rightarrow \boxed{\omega = \frac{+2eV_0}{\hbar}}$$

$$\int_{s(0)}^{s(t)} ds = -\frac{2eV_0}{\hbar} \int_{t=0}^t dt = -\frac{2eV_0 t}{\hbar}$$

$$\Rightarrow s(t) = s(0) - \frac{2eV_0 t}{\hbar}$$

$$\boxed{J = J_0 \sin\left(s(0) - \frac{2eV_0 t}{\hbar}\right)}$$



**Josephson Characteristics**

$$V_c = \frac{\text{Energy gap}}{e}$$

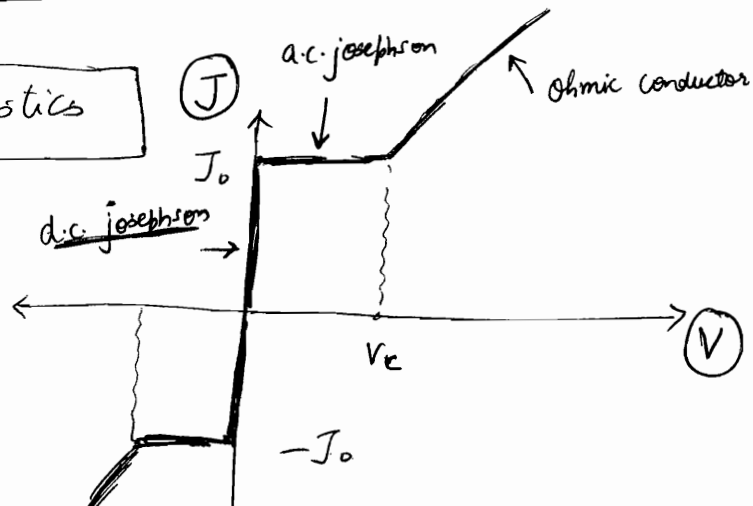

< Read High Temperature Superconductors from page 299, 300

## London Equations

London Equations explain the phenomenon of magnetic flux penetration inside a superconductor.

1<sup>st</sup> eqn

let  $n, \vec{v}$  be density & velocity of superconducting electrons.

Now, inside the superconductor

$$m \left( \frac{d\vec{v}}{dt} \right) = -e\vec{E}$$

$$\Rightarrow \left( \frac{d\vec{v}}{dt} \right) = - \left( \frac{e\vec{E}}{m} \right) \quad \text{--- (1)}$$

Also  $\vec{J} = -ne\vec{v}$

$$\Rightarrow \frac{d\vec{J}}{dt} = -ne \left( \frac{d\vec{v}}{dt} \right) \quad \text{--- (2)}$$

$$\Rightarrow \boxed{\frac{d\vec{J}}{dt} = + \left( \frac{ne^2}{m} \right) \vec{E}} \quad \text{London's 1<sup>st</sup> equation}$$

2<sup>nd</sup> eqn

Taking curl of 1<sup>st</sup> equation of London,

$$\vec{\nabla} \times \left( \frac{d\vec{J}}{dt} \right) = + \left( \frac{ne^2}{m} \right) (\vec{\nabla} \times \vec{E})$$

From Maxwell equation,  $\vec{\nabla} \times \vec{E} = - \left( \frac{\partial \vec{B}}{\partial t} \right)$

Hence  $\vec{\nabla} \times \left( \frac{\partial \vec{J}}{\partial t} \right) = - \frac{ne^2}{m} \left( \frac{\partial \vec{B}}{\partial t} \right)$

$$\Rightarrow \boxed{\vec{\nabla} \times \vec{J} = - \frac{ne^2}{m} \vec{B}} \quad \text{London's 2<sup>nd</sup> equation}$$

## Explanation of flux penetration

From Maxwell Equations,

$$\vec{\nabla} \times \vec{B} = \mu_0 \vec{J}$$

Taking curl,

$$\vec{\nabla} \times (\vec{\nabla} \times \vec{B}) = \mu_0 (\vec{\nabla} \times \vec{J})$$

(from London equation)

$$\Rightarrow \vec{\nabla} (\vec{\nabla} \cdot \vec{B}) - \nabla^2 \vec{B} = \mu_0 \left[ - \frac{ne^2}{m} \vec{B} \right]$$

$$\Rightarrow \nabla^2 \vec{B} = \left( \frac{\mu_0 ne^2}{m} \right) \vec{B}$$

let  $\sqrt{\frac{m}{\mu_0 ne^2}} = \lambda$  : London's penetration depth

$$\Rightarrow \nabla^2 \vec{B} = \frac{1}{\lambda^2} \vec{B}$$

$$\Rightarrow \boxed{B = B_0 e^{-\frac{x}{\lambda}}}$$

where  $B_0$  is the field at surface &  $x$  is the depth inside the superconductor.

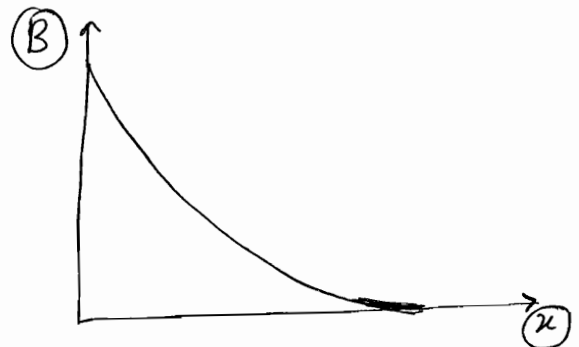

<https://ourstudycircle.in/upscpdf/>

## LONG QUESTIONS

1. State and prove the Bloch theorem. Discuss its importance in the band theory.
2. Discuss the formation of allowed and forbidden energy bands on the basis of the Kronig-Penney model. Discuss the extreme conditions when energy levels are either discrete or continuous. What is the effect of changing the binding energy of electron on the energy bands?
3. Prove that the motion of electrons through the periodic potential in solids gives rise to the band structure.
4. What are Bloch functions? Explain the origin of allowed and forbidden bands for electrons in solids. What is the number of orbitals in an energy band?
5. Describe the periodic zone scheme, extended zone scheme and reduced zone scheme for representing  $E-k$  relationships.
6. Discuss the motion of electrons in one-dimension according to the band theory and show the variation of energy, velocity and effective mass as a function of wave-vector.
7. What is meant by the effective mass of an electron? What is its significance? Show that the effective mass of an electron in a crystal is inversely proportional to the second derivative of the  $E-k$  curve. Discuss the conditions when the effective mass of an electron becomes positive, negative and infinity.

## PROBLEMS

1. The potential of an electron in a one-dimensional lattice is of the same type as that used in the Kronig-Penney model. Assuming

$$V_0 ab \ll \hbar^2 / m,$$

prove that the energy band gap at  $k = \pi/a$  is  $2V_0 b/a$ .

2. A one-dimensional lattice of spacing  $a$  has a potential distribution of the type as considered in the Kronig-Penney model. The value of the potential is  $-V$  at each lattice point and abruptly changes to zero at a distance of  $0.1a$  on either side of the lattice point. Determine the width of the first energy gap in the electron energy spectrum. (0.37 V)

• Properties

• Generation rate

• Energy levels

•  $\sigma$  vs  $f(T)$

$S$

$10^{-8}$

conductors

$\approx 0 \text{ eV}$

## SEMICONDUCTORS

CHAPTER - VII

$\approx 1 \text{ eV}$

semiconductors

$\approx 5 \text{ eV}$

$10^{-4}$  to  $10^{-8}$

insulators

## 5 Properties of Semiconductors

## 7.1 INTRODUCTION

Semiconductors are materials which have electrical conductivities lying between those of good conductors and insulators. The resistivity of semiconductors varies from  $10^{-5}$  to  $10^{14}$  ohm-m as compared to the values ranging from  $10^{-8}$  to  $10^{-6}$  ohm-m for conductors and from  $10^7$  to  $10^8$  ohm-m for insulators. There are elemental semiconductors such as germanium and silicon which belong to Group IV of the periodic table and ~~there are also~~ ~~of about  $0.6 \text{ eV}$  and  $1.5 \text{ eV}$  band gap respectively.~~ Besides these, there are certain compound semiconductors such as gallium arsenide (GaAs), indium phosphide (InP), cadmium sulphide (CdS), etc. which are formed from the combinations of the elements of Groups III and V, or Groups II and VI. Another important characteristic of the semiconductors is that they have small band gap. The band gap of semiconductors varies from 0.2 to 2.5 eV which is quite small as compared to that of insulators. The band gap of a typical insulator such as diamond is about 6 eV. This property determines the wavelength of radiation which can be emitted or absorbed by the semiconductor and hence helps to construct devices such as light emitting diodes (LEDs) and lasers. All the semiconductors have negative temperature coefficient of resistance. The band gap energies for the elements of Group IV at 0 K are as follows:

C (diamond)

Ge

Si

Sn (grey)

Pd

5.51 eV

0.75 eV

1.16 eV

0.08 eV

$\approx 0$

At room temperature, diamond behaves as an insulator, Ge and Si as semiconductors and Sn and Pd as conductors.

The importance of semiconductors is further increased due to the fact that the conductivity and the effective band gaps of these materials can be modified by the introduction of impurities which strongly affect their elec-

tronic and optical properties. The process of introduction of impurities in semiconductors in a precisely controlled manner is called *doping*. Depending on the nature of impurities added, the semiconductors are classified as follows:

- (A) Pure or intrinsic semiconductors.
- (B) Impurity or extrinsic semiconductors

The intrinsic semiconductors are pure semiconductors in which no impurity atoms are added, whereas the extrinsic semiconductors are doped semiconductors in which suitable impurity atoms are added to modify the properties. In the present chapter, the effects of impurities and charge carrier concentrations in semiconductors are discussed.

## 7.2 PURE OR INTRINSIC SEMICONDUCTORS

As stated above, the intrinsic semiconductors such as pure Ge or Si are undoped semiconductors. The electrical conductivity of this type of semiconductor is solely determined by thermally generated carriers. To understand the mechanism of conduction, we consider the bonding between

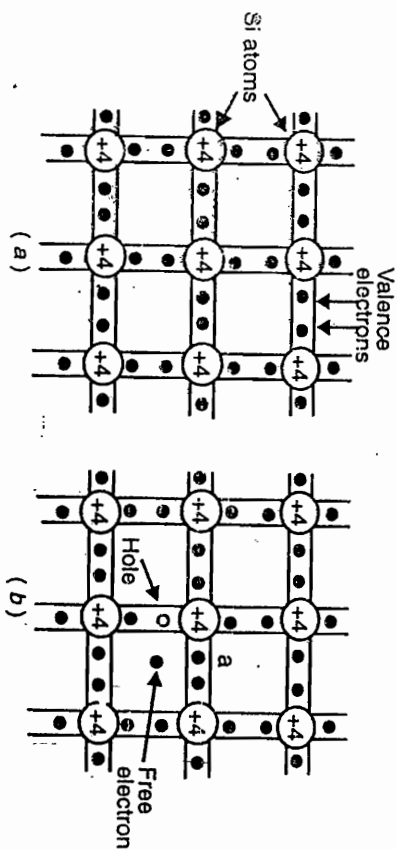

Fig. 7.1. (a) A two-dimensional representation of Si crystal  
(b) Silicon crystal containing an electron-hole pair.

atoms in these semiconductors. Consider, for example, the case of silicon with atomic number 14. Each silicon atom has four valence electrons and can form four covalent bonds with four neighbouring silicon atoms which are directed along the corners of a regular tetrahedron. The silicon crystal, therefore, exhibits a three-dimensional regular network type structure which, for simplicity, is represented by a two-dimensional network as shown in Fig. 7.1a. Apparently, all the valence electrons in a silicon crystal participate in the formation of covalent bonds and no electron is free to cause conduction

particularly at 0 K. Hence pure silicon behaves as an insulator at 0 K. As the temperature increases above 0 K, some of the valence electrons may acquire sufficient thermal energy to break their covalent bonds and become free from the influence of cores of the atoms. These electrons move randomly in the crystal and are referred to as the *conduction electrons*. Each escaped electron leaves behind an empty space called a *hole* which also acts as a current carrier. Thus when a valence electron breaks away from a covalent bond, an electron-hole pair is generated and two carriers of electricity are produced as shown in Fig. 7.1b. When a valence electron located adjacent to a hole acquires sufficient thermal energy, it may jump into the hole position to reconstruct the broken covalent bond and a hole is created at the initial position of the electron. Thus the motion of an electron may also be regarded as the motion of a hole in the opposite direction. These electrons and holes move in opposite directions under the effect of an external electric field and constitute the current.

The energy band diagram of the intrinsic semiconductor is shown in Fig. 7.2. At 0 K, the valence band is completely filled and the conduction band is completely empty. The semiconductor, therefore, behaves as an insulator. The electrons present in the valence band do not conduct as these are bound to their respective cores. As temperature increases, some of the valence band electrons acquire sufficient thermal energy to jump to the conduction band leaving behind an equal number of holes in the valence band. The electrons in the conduction band and holes in the valence band behave as free carriers and increase the conductivity of the material. The conditions for the movement of electrons are, however, different from the conditions for movement of holes: the electrons move when the conduction band is nearly empty and the holes move when the valence band is nearly full. Thus the electrons move mainly under the influence of the applied field while the holes move under the combined effect of the applied electric field and the ionic field of the lattice. Thus the properties such as effective mass, mobility, etc. of a hole are quite different from the corresponding properties of electrons. For example, a hole has larger effective mass and lower mobility than the corresponding values for an electron. The charge of a hole is equal and opposite to that of an electron. These properties have been described in the previous chapter. It is now apparent that, in an intrinsic semiconductor, the number of electrons,  $n_i$ , in the conduction band is always equal to the number of holes,  $p_i$ , in the valence band, i.e.,  $n_i = p_i$ , and either one of these is called the *intrinsic carrier concentration*.

Besides the generation of free electron-hole pairs, there is another process called *recombination* of carriers in semiconductors. A free electron

1. Mobility of a carrier is the velocity acquired by it in a unit electric field.

moving randomly in a semiconductor may encounter a hole and combine with it so as to reconstruct the broken covalent bond. Thus the electron-hole pair is destroyed and the free electron is converted into the bound electron. This recombination process is equivalent to an electron jumping from the conduction band to the valence band and occurs with the release of energy equal to the band gap energy in the form of electromagnetic radiation as shown in Fig. 7.2. (In an intrinsic semiconductor,

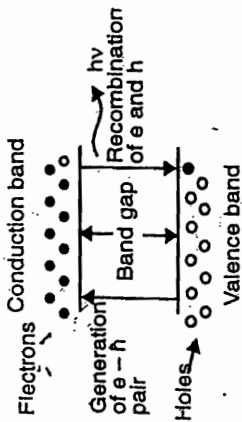

Fig. 7.2. Energy band diagram of an intrinsic semiconductor showing generation and recombination of an electron and a hole.

the rate of generation of carriers,  $g$ , depends on the temperature and nature of the material. The recombination rate,  $R$ , on the other hand, depends on the concentration of electrons and holes in a material at that temperature. (In equilibrium, the generation rate just equals the recombination rate, i.e.,

$$g = R = C \cdot n \cdot p_i$$

where  $C$  is a proportionality constant which depends on the nature of the material. Since in an intrinsic semiconductor,  $n_i = p_i$ , we have

$$g = R = C n_i^2 \quad (7.1)$$

For a given temperature, the quantity  $n_i$  is a constant and depends only on the nature of the semiconductor. It will be realized later that the constant  $C$  is related to the densities of states of electrons and holes at the conduction band and valence band edges respectively.

### 7.3 IMPURITY OR EXTRINSIC SEMICONDUCTORS

(The intrinsic semiconductors, as such, are of little importance owing to their very small and fixed conductivity. The introduction of impurity atoms, i.e. doping, is the most efficient and convenient method of increasing and altering the conductivity of an intrinsic semiconductor.) Depending on the type of doping, excess electrons or holes are generated in the material which are free to conduct electricity. (The impurity atoms frequently employed to dope pure silicon or germanium are the elements of Group III and Group V of the periodic table. These impurity atoms are referred to as acceptor or  $p$ -type and donor or  $n$ -type impurities as they contribute excess holes and electrons respectively to the semiconducting material.) The semiconductor is accordingly known as  $p$ -type or  $n$ -type semiconductor. (The dopants are added in the ratio of about  $1$  in  $10^6$  to  $10^8$  atoms of the semiconducting material. Such a small quantity of dopants does not bring about any structural changes in the semiconductor as the impurity atoms

replace the regular atoms in the crystal. However, the conductivity of the semiconductors is greatly affected by such substitutions.

#### 7.3.1 Donor or $n$ -type Semiconductor

(When a pentavalent impurity atom of Group V, such as phosphorus, arsenic or antimony, is introduced into silicon, four of its five valence electrons form covalent bonds with the neighbouring four silicon atoms while the fifth valence electron remains loosely bound to its nucleus as shown in Fig. 7.3a. A small but definite amount of energy is required to detach this fifth electron from its nucleus and make it free to conduct. The energy required is, however, quite small as compared to the energy required for breaking a covalent bond and can be easily provided by thermal agitation inside the crystal.)

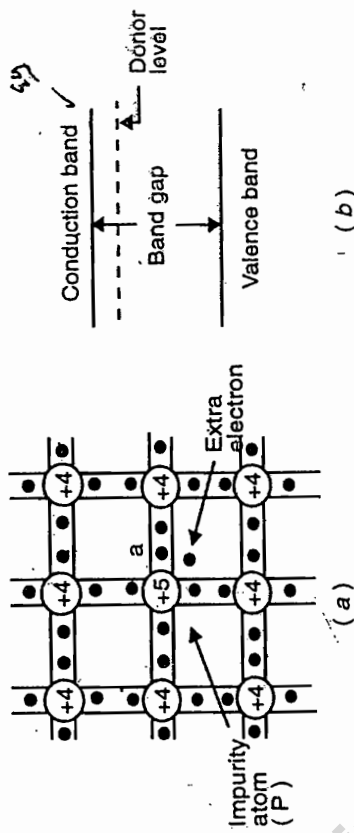

Fig. 7.3. (a) A pentavalent impurity atom (P) in a silicon crystal. (b) Energy level diagram of an  $n$ -type semiconductor.

The energy level corresponding to the fifth valence electron lies in the band gap just below the conduction band edge as shown in Fig. 7.3b. This level is called the donor level. The depth of the donor level below the conduction band is merely about 0.01 eV for Ge and 0.03 eV for Si. The electrons are, therefore, easily transferred to the conduction band leaving behind positively charged immobile impurity ions. Thus each pentavalent impurity atom donates one free electron to the semiconductor. Such impurities are, therefore, known as donors or  $n$ -type impurities and the semiconductor containing such impurity atoms is known as an  $n$ -type semiconductor. In these semiconductors, the current is carried mainly by electrons which are called majority carriers. The thermally generated holes are called minority carriers. The electron concentration,  $n$ , is obviously quite large as compared to hole concentration,  $p$ , but their product always remains constant.

The energy gap is also called Forbidden energy gap.

i.e.,

$$np = n_i p_i = n_i^2 \quad (7.2)$$

where  $n_i$  and  $p_i$  are the intrinsic values of the carrier concentration. This relationship is called the law of mass-action and will be derived later.)

### 7.3.2 Acceptor or p-type Semiconductor

If a trivalent impurity atom of Group III, such as boron, aluminium, gallium or indium, is introduced into silicon, it forms three covalent bonds with the neighbouring three silicon atoms while the fourth bond is not completed due to the deficiency of one electron. This incomplete bond is shown by broken line in Fig. 7.4a where the small circle (marked 'a') represents the electron deficiency. Thus the trivalent impurity atom has a tendency to accept one electron (say 'b') from a neighbouring silicon atom to complete the fourth covalent bond. This process requires a small amount of energy which is easily provided by the thermal agitation in the crystal. The transferred electron leaves behind a broken covalent bond, i.e., a hole, at position 'b' on the silicon atom which acts as a current carrier.

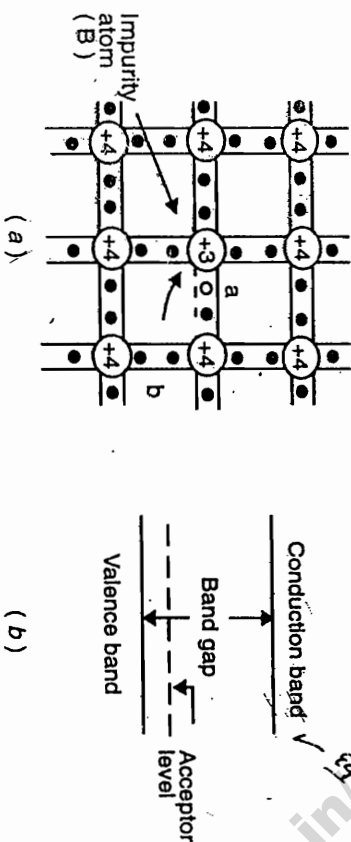

Fig. 7.4. (a) A trivalent impurity atom (B) in a silicon crystal.

(b) Energy level diagram of a p-type semiconductor.

The energy level corresponding to the electron deficiency of the type 'a' is located just above the valence band and is called the acceptor level. The acceptor levels are located at a distance 0.046 to 0.16 eV above the top of the valence band in Ge and at about 0.046 to 0.16 eV in Si. An electron can be easily transferred from the valence band to the acceptor level by providing this small amount of energy. This creates a hole in the valence band which acts as a mobile current carrier. The negatively charged impurity atom, however, remains stationary in the crystal. Thus each trivalent impurity atom can accept an electron from a neighbouring silicon atom to produce a hole in the semiconductor. Such impurities are, therefore, known as acceptors or p-type impurities and the semiconductor containing such impurity atoms is known as a p-type semiconductor. In these semicon-

ductors, holes are the majority carriers and thermally generated electrons are the minority carriers. In this case,  $p$  is quite large as compared to  $n$  but the law of mass-action still holds, i.e.,  $np = n_i p_i = n_i^2$ . It may also be noted that in either type of semiconductors, the overall charge neutrality is maintained as no charge is added to or removed from the material.)

### 7.4 DRIFT VELOCITY, MOBILITY AND CONDUCTIVITY OF INTRINSIC SEMICONDUCTORS

At finite temperatures, due to thermal agitation and lattice vibrations, some of the valence band electrons are always present in the conduction band, i.e., at ordinary temperatures, an intrinsic semiconductor always contains some free electrons in the conduction band and an equal number of holes in the valence band. In the absence of any applied electric field, these electrons and holes move in random directions and constitute no current. When an electric field is applied, these electrons and holes get accelerated towards the opposite ends of the field and their velocity begins to increase. This increase in velocity, however, does not continue indefinitely because of the collisions of these carriers with the various types of obstacles (such as atoms, molecules, phonons, etc. present in the semiconductor). Depending on the mean free path, the carriers acquire an average increment in velocity which is called the drift velocity. This extra velocity acquired by the carriers in the presence of an applied electric field is called the drift velocity and is denoted by  $v_d$ . It is proportional to the strength  $\mathcal{E}$  of the applied electric field, i.e.,

$$v_d \propto \mathcal{E}$$

or

$$v_d = \mu \mathcal{E} \quad (7.3)$$

where the constant  $\mu$  is called the mobility of the charge carrier and is defined as the drift velocity acquired by a carrier per unit electric field strength.

In an intrinsic semiconductor, since the electrons move in nearly empty conduction band while holes move in nearly full valence band, the properties such as mobility, conductivity, etc. of electrons are, in general, different from those of holes. Let  $v_{dn}$ ,  $\mu_n$  and  $n$  denote the drift velocity, mobility and concentration of electrons respectively in the conduction band. Then current density due to electrons is given by

$$J_n = nev_{dn} \quad (7.4)$$

where  $e$  is the electronic charge. We can write (7.3) for the electrons as

$$v_{dn} = \mu_n \mathcal{E}$$



Therefore, from Eq. (7.4), we obtain

$$J_n = ne\mu_n \mathcal{E} \quad (7.5)$$

Comparing it with Ohm's law, i.e.,

$$J_n = \sigma_n \mathcal{E},$$

$$\sigma_n = ne\mu_n \quad (7.6)$$

Similarly, we can write the expression for the conductivity due to holes in the valence band as

$$\sigma_p = pe\mu_p \quad (7.7)$$

where  $p$  and  $\mu_p$  represent the concentration and mobility of holes respectively. Thus the total conductivity of the material is

$$\sigma = \sigma_n + \sigma_p$$

$$= e(n\mu_n + p\mu_p) \quad (7.8)$$

For an intrinsic semiconductor,

$$n = p = n_i$$

Therefore, Eq. (7.8) becomes

$$\sigma = en_i(\mu_n + \mu_p) \quad (7.9)$$

It is important to note that in semiconductors, the movement of carriers or the flow of current is, in fact, the consequence of the following two processes:

- (i) drift of carriers under the effect of an applied field; the resulting current is called the drift current.
- (ii) diffusion of carriers under the effect of concentration gradient of dopants present inside the semiconductor; the corresponding current is called the diffusion current.

In the above treatment, we have considered only the drift current contribution. The diffusion current contribution is absent in semiconductors having a uniform distribution of impurities.

### Variation of Conductivity with Temperature

Assuming mobilities to be independent of temperature, the temperature dependence of conductivity arises because of the variation of intrinsic carrier concentration,  $n_i$ , with temperature. It will be proved that  $n_i$  is given by

$$n_i = \frac{2(2\pi kT)^{3/2}}{h^3} (m_n^* m_p^*)^{3/4} \exp\left(-\frac{E_g}{2kT}\right) \quad (7.10)$$

ये प्रकृतिक ताप के साथ ही

where  $m_n^*$  and  $m_p^*$  represent the effective masses of an electron and a hole respectively,  $E_g$  is the band gap,  $k$  is the Boltzmann's constant and  $T$  is the absolute temperature. Substituting  $n_i$  from Eq. (7.10) into (7.9), we get

$$\sigma = e(\mu_n + \mu_p) \frac{2(2\pi kT)^{3/2}}{h^3} (m_n^* m_p^*)^{3/4} \exp\left(-\frac{E_g}{2kT}\right) \quad (7.11)$$

which gives

$$\ln \sigma = -\left(\frac{E_g}{2k}\right) \frac{1}{T} + \frac{3}{2} \ln T + \text{constant} \quad (7.12)$$

The first term on the right hand side is the dominant term. The plot of  $\ln \sigma$  versus  $1/T$  is a straight line as shown in Fig. 7.5. The slope of the line gives an estimate of the band gap of the semiconductor.

$$E_g = 2k * \tan \theta$$

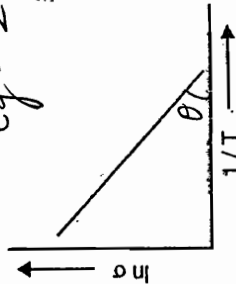

Fig. 7.5. Plot of  $\ln \sigma$  versus  $1/T$ .

### 7.5 CARRIER CONCENTRATION AND FERMI LEVEL FOR INTRINSIC SEMICONDUCTOR

The concentration of electrons and holes in a semiconductor can be obtained from the knowledge of the densities of available states in the valence band and the conduction band as well as the Fermi-Dirac distribution function. The expression for the Fermi energy is then obtained from these carrier concentrations.

#### 7.5.1 Electron Concentration in the Conduction Band

Referring to Eq. (5.44), the number of free electrons per unit volume in an energy range  $E$  and  $E + dE$  can be written as

$$dn = D(E) f(E) dE \quad (7.13)$$

where  $D(E)$  is the density of states defined as the total number of allowed electronic states per unit volume in a semiconductor and  $f(E)$  is the Fermi distribution function representing the probability of occupation of a state with energy  $E$ . The expression for  $f(E)$  is given by Eq. (5.28) as

$$f(E) = \frac{1}{\exp\left(\frac{E - E_F}{kT}\right) + 1} \quad (7.14)$$

whereas that for  $D(E)$ , which is strictly valid for free electrons, is obtained from Eq. (5.40) as

note that we are taking per unit volume and fermions have

$$D(E) = \frac{4\pi}{h^3} (2m)^{3/2} E^{1/2} \quad (7.15)$$

Using Eqs. (7.15) and (7.13), we obtain

$$dn = \frac{4\pi}{h^3} (2m)^{3/2} E^{1/2} f(E) dE$$

It is apparent from Fig. 7.6 that an electron occupying an energy state  $E$  in the conduction band, in fact, possesses the kinetic energy  $(E - E_c)$ . Therefore, in Eq. (7.15),  $E$  must be replaced by  $(E - E_c)$ . Thus Eq. (7.16) becomes

$$dn = \frac{4\pi}{h^3} (2m_n^*)^{3/2} (E - E_c)^{1/2} \frac{1}{\exp\left(\frac{E - E_F}{KT}\right) + 1} dE \quad (7.17)$$

where  $m_n^*$  is the effective mass of the electron in the conduction band. The concentration of electrons,  $n$ , in the conduction band is obtained by integrating Eq. (7.17) from  $E = E_c$  to  $E = \infty$ , i.e.,

$$n = \frac{4\pi}{h^3} (2m_n^*)^{3/2} \int_{E_c}^{\infty} \frac{(E - E_c)^{1/2} dE}{\exp\left(\frac{E - E_F}{KT}\right) + 1} \quad (7.18)$$

Now, near room temperature,  $KT \approx 0.026$  eV. Therefore, for energies greater than  $E_c$ , we have

$$1 + \exp\left(\frac{E - E_F}{KT}\right) \approx \exp\left(\frac{E - E_F}{KT}\right)$$

$$\therefore n = \frac{4\pi}{h^3} (2m_n^*)^{3/2} \int_{E_c}^{\infty} (E - E_c)^{1/2} \exp\left[-\left(\frac{E - E_F}{KT}\right)\right] dE$$

$$= \frac{4\pi}{h^3} (2m_n^*)^{3/2} \exp\left(\frac{E_F - E_c}{KT}\right) \int_{E_c}^{\infty} (E - E_c)^{1/2} \exp\left[-\left(\frac{E - E_c}{KT}\right)\right] dE$$

Let  $\frac{E - E_c}{KT} = x$   
 $dE = KT dx$

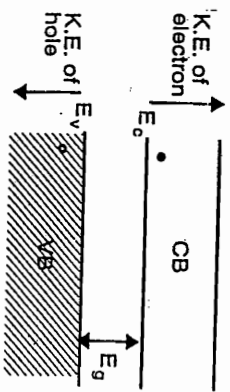

Fig. 7.6. Band model of an intrinsic semiconductor.

For  $E = E_c$ ,  $x = 0$

$$n = \frac{4\pi}{h^3} (2m_n^*)^{3/2} \exp\left(\frac{E_F - E_c}{KT}\right) \int_0^{\infty} x^{1/2} (KT)^{1/2} e^{-x} KT dx$$

$$= \frac{4\pi}{h^3} (2m_n^* KT)^{3/2} \exp\left(\frac{E_F - E_c}{KT}\right) \int_0^{\infty} x^{1/2} e^{-x} dx$$

Now

Standard  $\int_0^{\infty} x^{1/2} e^{-x} dx = \left(\frac{\pi}{4}\right)^{1/2} = \frac{\sqrt{2}}{2} = \frac{1}{2} \sqrt{\pi}$

$$n = 2 \left(\frac{2\pi m_n^* KT}{h^2}\right)^{3/2} \exp\left[-\left(\frac{E_c - E_F}{KT}\right)\right] \quad (7.19)$$

From Eq. (7.14), the probability of occupancy of level  $E_c$  is given by

$$f(E_c) = \frac{1}{1 + \exp\left(\frac{E_c - E_F}{KT}\right)} \approx \exp\left[-\left(\frac{E_c - E_F}{KT}\right)\right]$$

Therefore, Eq. (7.19) becomes

$$n = 2 \left(\frac{2\pi m_n^* KT}{h^2}\right)^{3/2} f(E_c)$$

The first term on the right hand side must represent the effective density of states of electrons at the conduction band edge. Denoting it by  $N_c$ , we have

$$n = N_c \exp\left[-\left(\frac{E_c - E_F}{KT}\right)\right] \quad (7.20)$$

where exponentially decreasing afterwards

$$N_c = 2 \left(\frac{2\pi m_n^* KT}{h^2}\right)^{3/2} \quad (7.21)$$

For silicon,

\* Justification कि उभार कि उभार करार करी !!  
 In density of states we are interested by  $e^-$  conduction band level से किताना उपर है उभर hole valence band level से किताना नीचे है !

$$N_c = 2.8 \times 10^{25} \left( \frac{T}{300} \right)^{3/2} \text{ m}^{-3}$$

### 7.5.2 Hole Concentration in the Valence Band

Note that in the energy range  $E$  and  $E + dE$  can be written as

$$dp = D(E)[1 - f(E)]dE \tag{7.22}$$

where we have replaced  $f(E)$  by  $[1 - f(E)]$  which represents the probability of an energy state  $E$  not to be occupied by an electron, i.e., the probability of finding a hole in the energy state  $E$ . Now

$$1 - f(E) = 1 - \frac{1}{1 + \exp\left(\frac{E - E_F}{kT}\right)} = \frac{\exp\left(\frac{E - E_F}{kT}\right)}{1 + \exp\left(\frac{E - E_F}{kT}\right)} \quad *$$

In the valence band, since  $E < E_F$  the exponential term in the denominator may be neglected in comparison to unity. Thus, we get

$$1 - f(E) \approx \exp\left(\frac{E - E_F}{kT}\right) \tag{7.23}$$

Probability of finding a hole

It follows that the probability of finding holes decreases exponentially with increase in depth into the valence band. Also, the kinetic energy of a hole in the energy state  $E$  in the valence band is  $(E_v - E)$ . Therefore, the density of states per unit volume in the valence band can be written as

$$D(E) = \frac{4\pi}{h^3} (2m_p^*)^{3/2} (E_v - E)^{1/2} \quad *$$

where  $m_p^*$  is the effective mass of a hole in the valence band. Using Eqs. (7.23) and (7.24) in Eq. (7.22) and integrating from  $E = -\infty$  to  $E = E_v$ , we obtain the hole concentration in the valence band as

$$p = \frac{4\pi}{h^3} (2m_p^*)^{3/2} \int_{-\infty}^{E_v} (E_v - E)^{1/2} \exp\left(\frac{E - E_F}{kT}\right) dE$$

$$= \frac{4\pi}{h^3} (2m_p^*)^{3/2} \exp\left(\frac{E_v - E_F}{kT}\right) \int_{-\infty}^{E_v} (E_v - E)^{1/2} \exp\left(\frac{E - E_v}{kT}\right) dE$$

Let  $\frac{E_v - E}{kT} = x$

$$dE = -kT dx$$

$\therefore$  For  $E = E_v, x = 0$

$$p = \frac{4\pi}{h^3} (2m_p^*)^{3/2} \exp\left(\frac{E_v - E_F}{kT}\right) \int_0^{\infty} x^{1/2} (kT)^{1/2} e^{-x} (-kT) dx$$

$$= \frac{4\pi}{h^3} (2m_p^*)^{3/2} \exp\left(\frac{E_v - E_F}{kT}\right) (kT)^{3/2} \int_0^{\infty} x^{1/2} e^{-x} dx$$

$$= \frac{4\pi}{h^3} (2m_p^* kT)^{3/2} \exp\left(\frac{E_v - E_F}{kT}\right) \left(\frac{\pi}{4}\right)^{1/2}$$

$$= 2 \left( \frac{2\pi m_p^* kT}{h^2} \right)^{3/2} \exp\left[-\left(\frac{E_F - E_v}{kT}\right)\right] \quad \text{--- (7.25)}$$

or 
$$p = N_v \exp\left[-\left(\frac{E_F - E_v}{kT}\right)\right] \tag{7.26}$$

where

$$N_v = 2 \left( \frac{2\pi m_p^* kT}{h^2} \right)^{3/2}$$

*$b' \omega^2$  exponentially necessary below*

represents the effective density of holes at the valence band edge. For silicon,

$$N_v = 2.8 \times 10^{25} \left( \frac{T}{300} \right)^{3/2} \text{ m}^{-3}$$

The electron and hole concentrations given by Eqs. (7.20) and (7.26) respectively are valid for both intrinsic and extrinsic materials. For intrinsic materials, these equations can also be written as

$$n_i = N_c \exp\left[-\left(\frac{E_c - E_i}{kT}\right)\right], \quad p_i = N_v \exp\left[-\left(\frac{E_i - E_v}{kT}\right)\right] \tag{7.28}$$

where the Fermi level  $E_F$  has been replaced by the intrinsic level  $E_i$ .

### 7.5.3 Fermi Level

For an intrinsic semiconductor,

Therefore, from Eqs. (7.20) and (7.26), we get

$$N_c \exp \left[ - \left( \frac{E_c - E_F}{kT} \right) \right] = N_v \exp \left[ - \left( \frac{E_F - E_v}{kT} \right) \right]$$

or  $\exp \left( \frac{2E_F - E_c - E_v}{kT} \right) = \frac{N_v}{N_c}$

or  $\frac{2E_F - E_c - E_v}{kT} = \ln \left( \frac{N_v}{N_c} \right)$

Using Eqs. (7.21) and (7.27) in Eq. (7.29), we obtain

$$E_F = E_i = \frac{E_c + E_v}{2} + \frac{kT}{2} \ln \left( \frac{N_v}{N_c} \right) \quad (7.29)$$

By equating (1) and (2), we get  $E_F = \frac{E_c + E_v}{2} + \frac{3}{4} kT \ln \left( \frac{m_p^*}{m_n^*} \right)$  (7.30)

At 0 K,  $E_F = \frac{E_c + E_v}{2}$  (7.31)

i.e., the Fermi level lies in the middle of the conduction band and valence band. This is also true at all other temperatures provided  $m_p^* = m_n^*$ . However, in general,  $m_p^* > m_n^*$  and the Fermi level is raised slightly as  $T$  exceeds 0 K. For Si at 300 K, the increase in Fermi energy is about 0.01 eV only which may be neglected for all practical purposes.

**7.5.4 Law of Mass Action and Intrinsic Carrier Concentration**

Since for an intrinsic semiconductor,  $n = p = n_i$ , the Eqs. (7.20) and (7.26) yield

$$n p = n_i^2 = N_c N_v \exp \left( - \frac{E_g}{kT} \right) = N_c N_v \exp \left( - \frac{E_g}{kT} \right) \quad (7.32)$$

Using Eqs. (7.21) and (7.27), the above expression becomes

$$n p = n_i^2 = 4 \left( \frac{2\pi kT}{h^2} \right)^3 (m_n^* m_p^*)^{3/2} e^{-E_g/kT} \quad (7.33)$$

This shows that, for a given semiconductor, the product of electron and hole concentrations is a constant at a given temperature and is equal to the square of the intrinsic carrier concentration. This is called the law of mass action and holds for both intrinsic and extrinsic semiconductors. If impurity atoms are added to a semiconductor to increase  $n$ , there will be a corresponding decrease in  $p$  such that the product  $np$  remains constant. Thus we always have

$$n p = n_i^2 \quad (7.34)$$

The intrinsic carrier concentration can be directly obtained from Eq. (7.32) or (7.33) as

$$n_i = (N_c N_v)^{1/2} \exp \left( - \frac{E_g}{2kT} \right) \quad (7.35)$$

For pure Ge at 300 K, the intrinsic electron concentration is about  $2.4 \times 10^{19} \text{ m}^{-3}$  when the concentration of germanium atoms is  $4.4 \times 10^{28} \text{ m}^{-3}$ . This shows that, at ordinary temperatures, only about five covalent bonds per  $10^{10}$  atoms of germanium are broken and contribute to intrinsic conduction. On the other hand, in metals such as copper, about  $10^{28}$  electrons per cubic metre are available for conduction.

**7.6 CARRIER CONCENTRATION, FERMI LEVEL AND CONDUCTIVITY FOR EXTRINSIC SEMICONDUCTOR**

As described earlier, the donor or acceptor levels are present in an extrinsic semiconductor depending on the type of impurity present. The concentration of donors or acceptors in a semiconductor affects the Fermi energy, the carrier concentration and the conductivity of the semiconductor. We consider the following cases :

**(a) N-type Semiconductor**

The energy level diagram for an n-type semiconductor is shown in Fig. 7.7. At 0 K, all the donors are in the unionized state, i.e., all the donor levels are occupied with electrons. As the temperature increases slightly, some of the donors get ionized and contribute electrons to the conduction band. Also, some of the valence band electrons may jump to the conduction

band leaving behind holes in the valence band. The number of holes produced in this process is, however, quite small. Therefore, the Fermi level must lie somewhere near the middle of the donor level and the bottom of the conduction band. We determine the equilibrium carrier concentration at a temperature  $T$ . Let there be  $N_d$  donors per unit volume occupying the donor levels with energy  $E_d$ . Assuming that  $E_F$  lies more than few  $kT$  below the conduction band, the electron concentration in the conduction band, as given by Eq. (7.20), is

$$n = N_c \exp\left[-\left(\frac{E_c - E_F}{kT}\right)\right] \quad (7.20)$$

The electron concentration must be equal to the sum of the concentration of ionized donors,  $N_d$ , in the donor levels and the concentration of thermally generated holes in the valence band, i.e.,

$$n = N_d^+ + p \quad (7.37)$$

If a sufficient number of donors are present to produce electrons in the conduction band, the concentration of thermally generated holes gets suppressed as a consequence of the law of mass action [Eq. (7.34)]. Thus  $p$  may be neglected in Eq. (7.37) which, therefore, becomes

$$n = N_d^+ \quad (7.38)$$

Also, from Eq. (7.34), the concentration of minority carriers (holes) is given by

$$p = \frac{n_i^2}{N_d^+} \quad (7.39)$$

and the concentration of ionized donors is calculated as

$$N_d^+ = N_d [1 - f(E_d)]$$

$$= N_d \left[ 1 - \frac{1}{1 + \exp\left\{-\left(\frac{E_F - E_d}{kT}\right)\right\}} \right]$$

$$= N_d \frac{\exp\left\{-\left(\frac{E_F - E_d}{kT}\right)\right\}}{1 + \exp\left\{-\left(\frac{E_F - E_d}{kT}\right)\right\}}$$

$$= N_d \exp\left[-\left(\frac{E_F - E_d}{kT}\right)\right] \quad (7.40)$$

where we have neglected the exponent term in the denominator assuming that  $E_F$  lies more than a few  $kT$  above  $E_d$ . Using Eqs. (7.20) and (7.40) in Eq. (7.38), we obtain

$$N_c \exp\left[-\left(\frac{E_c - E_F}{kT}\right)\right] = N_d \exp\left[-\left(\frac{E_F - E_d}{kT}\right)\right]$$

or  $\ln N_c - \left(\frac{E_c - E_F}{kT}\right) = \ln N_d - \left(\frac{E_F - E_d}{kT}\right)$

or  $-\frac{E_c - E_F}{kT} + \frac{E_F - E_d}{kT} = \ln N_d - \ln N_c$

$$E_F = \frac{E_d + E_c}{2} + \frac{kT}{2} \ln\left(\frac{N_d}{N_c}\right) \quad (7.41)$$

This gives the position of the Fermi level at moderate temperatures. Since  $N_c$  varies as  $T^{3/2}$  as given by Eq. (7.21), this equation is not valid for  $T \approx 0$  K. Also, it is not valid for  $T \rightarrow \infty$  because, at very high temperatures, the assumption of suppressing the holes does not hold good. The only valid information obtainable from this equation is that the Fermi level lies somewhere near the middle of the donor level and the conduction band edge at moderate temperatures. This is particularly true for those values of  $T$  and  $N_d$  for which the second term on the right hand side is negligible. As  $T$  increases, the Fermi level moves downwards and crosses the donor level. For sufficiently large temperatures, it drops to  $E_i/2$ , i.e., coincides with the intrinsic level  $E_i$ . This is, however, not apparent from Eq. (7.41). In such a case, the extrinsic semiconductor behaves like an intrinsic one. The variations of  $(E_F - E_i)$  with temperature for both  $n$  and  $p$  type silicon are shown in Fig. 7.8 for different impurity concentrations.

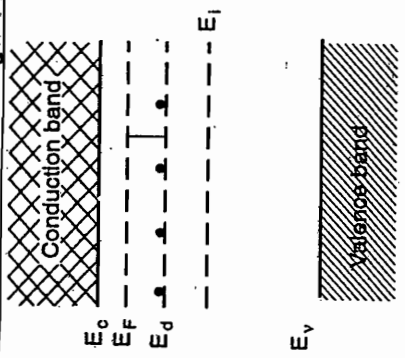

Fig. 7.7. Band model of an n-type semiconductor.

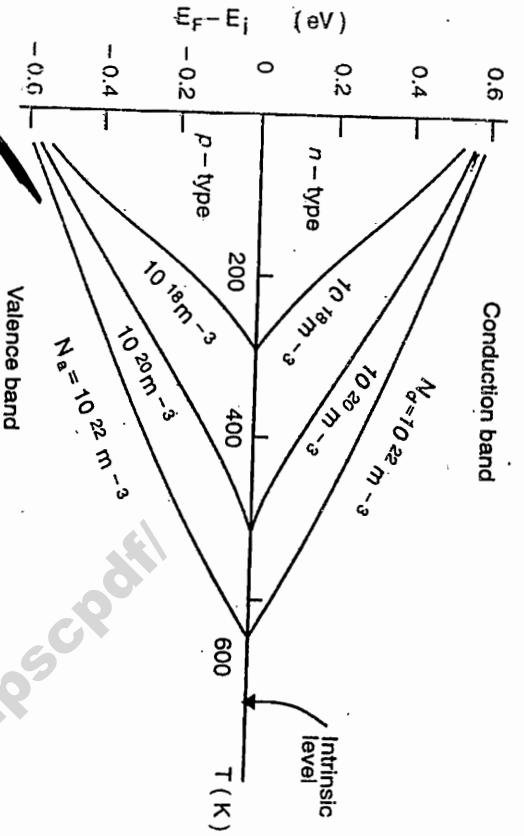

Fig. 7.8. Variations of Fermi level with temperature and impurity concentration for Si.

A direct relationship between the equilibrium carrier concentration and the position of the Fermi level relative to the intrinsic level, as obtained from Eqs. (7.20) and (7.28), is

$$n = n_i \exp \left( \frac{E_F - E_i}{KT} \right) \quad (7.42)$$

It is obvious from this equation that the equilibrium electron concentration approaches the intrinsic carrier concentration as  $E_F$  approaches  $E_i$ . Also, the electron concentration increases exponentially as the Fermi level moves away from  $E_i$  towards the conduction band. A similar relation for the hole concentration will be obtained later.

The free electron concentration in the conduction band is obtained by substituting the value of  $E_F$  from Eq. (7.41) into (7.20), i.e.,

$$\begin{aligned} n &= N_c \exp \left[ \frac{E_d - E_c}{2KT} + \frac{1}{2} \ln \left( \frac{N_d}{N_c} \right) \right] \\ &= N_c \left( \frac{N_d}{N_c} \right)^{1/2} \exp \left( \frac{E_d - E_c}{2KT} \right) \\ &= (N_d N_c)^{1/2} \exp \left( \frac{E_d - E_c}{2KT} \right) \end{aligned} \quad (7.43)$$

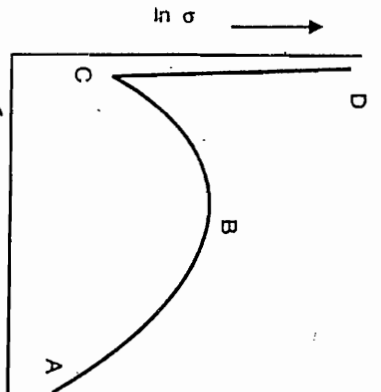

Fig. 7.9. Conductivity versus temperature for a typical n-type germanium sample.

Knowing the electron concentration,  $n$ , and the electron mobility,  $\mu_n$ , at any given temperature, the electrical conductivity can be calculated by using Eq. (7.45). The temperature dependence of electrical conductivity for an n-type germanium is shown in Fig. 7.9. The following conclusions can be drawn from this curve :

- (i) Starting from the very low temperature (about 10 K) corresponding to the point A, the conductivity increases with rise in temperature. This is due to the increase in the number of conduction electrons as a result of ionization of the donors. The conductivity attains a maximum value (point B) when all the donors are ionized. The temperature corresponding to this is about 50 K for a moderately doped n-type germanium.
- (ii) The conductivity decreases with further increase in temperature up to about room temperature (point C) and is attributed to the decrease in the value of mobility with rise in temperature. There is also an increase in the intrinsic conductivity but to a lesser extent.
- (iii) The sharp rise in conductivity from C to D is due to the large increase in intrinsic conductivity which offsets the decrease in mobility.

(b) P-type Semiconductor

The case of a p-type semiconductor can be treated in the same way as that of an n-type semiconductor. The energy level diagram for a p-type semiconductor is shown in Fig. 7.10. The acceptor impurity atoms occupy the acceptor levels,  $E_a$ , which lie above the valence band. For  $T > 0$  K, a

$$= (N_d N_c)^{1/2} \exp \left( \frac{-\Delta E}{2KT} \right) \quad (7.44)$$

where  $\Delta E = E_c - E_d$  represents the ionization energy of the donors. This shows that the carrier concentration at moderate temperatures varies as  $\sqrt{N_d}$ .

The electrical conductivity of an n-type semiconductor can be calculated from

$$\sigma = e n \mu_n \cong e N_d^+ \mu_n \quad (7.45)$$

where it has been assumed that the conduction is mainly due to electrons.

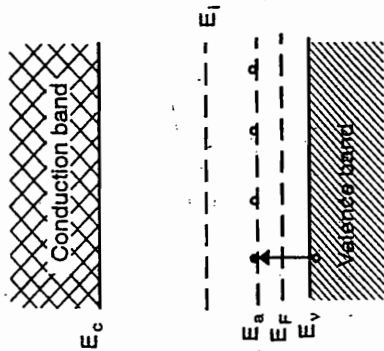

Fig. 7.10. Band model for a p-type semiconductor.

The concentration of ionized acceptors is given by

$$N_a^- = N_a f(E_a) = \frac{N_a}{1 + \exp\left(\frac{E_a - E_f}{kT}\right)} \tag{7.47}$$

Assuming  $(E_a - E_f)$  to be large as compared to  $kT$ , Eq. (7.47) can be written as

$$N_a^- \approx N_a \exp\left(\frac{E_f - E_a}{kT}\right) \tag{7.48}$$

The hole concentration in the valence band is given by Eq. (7.26) as

$$p = N_v \exp\left(-\frac{E_f - E_v}{kT}\right) \tag{7.26}$$

Using Eqs. (7.48) and (7.26) in Eq. (7.46), we obtain

$$N_v \exp\left(-\frac{E_f - E_v}{kT}\right) = N_a \exp\left(\frac{E_f - E_a}{kT}\right)$$

which, on simplification, gives

$$E_f = \frac{E_a + E_v}{2} - \frac{kT}{2} \ln\left(\frac{N_a}{N_v}\right) \tag{7.49}$$

As described earlier, the Fermi level at moderate temperatures lies near the middle of the acceptor level and the top of the valence band. It moves upwards with increase in temperature and finally coincides with the intrinsic level as shown in Fig. 7.8. (The expression (7.49) is not valid at very high temperatures where  $n$  cannot be neglected.)

Using Eqs. (7.26) and (7.28), we obtain an expression identical to Eq. (7.42), i.e.,

$$p = n_i \exp\left(\frac{E_i - E_f}{kT}\right) \tag{7.50}$$

It indicates that the equilibrium hole concentration approaches the intrinsic carrier concentration as  $E_f$  approaches  $E_i$ . Also,  $p$  increases exponentially as  $E_f$  moves away from  $E_i$  towards the valence band. An expression for the hole concentration in the valence band can be obtained by using Eq. (7.49) into (7.26) as in the previous case.

The electrical conductivity of a p-type semiconductor is given by

$$\sigma_p = e\mu_h p \approx eN_a^- \mu_p \tag{7.51}$$

where the conduction due to minority carriers has been ignored. The variation of conductivity with temperature is similar to that for the n-type semiconductor.

It also follows from Eqs. (7.45) and (7.51) that the increase in concentration of either type of impurity atoms increases the conductivity of a semiconductor. For impurity concentration ranging from  $10^{20}$  to  $10^{22} \text{ m}^{-3}$ , the resistivity of Si and Ge varies from  $10^{-3}$  to  $10^{-1} \text{ ohm-m}$ . If doping is heavy ( $10^{23}$  to  $10^{24} \text{ atoms/m}^3$ ), the conductivity of semiconductors becomes comparable to metals. Such semiconductors are called *degenerate semiconductors* and find applications in high power and high frequency devices.

(c) Mixed Semiconductor

In a semiconductor containing both n and p-type impurities, the law of electrical neutrality is written as

$$N_d^+ + p = N_a^- + n \tag{7.52}$$

Taking  $N_d^+ = N_a^-$  and using Eq. (7.34), we obtain

$$p = n = n_i$$

This shows that, for equal concentrations of donors and acceptors, the semiconductor behaves as pure or intrinsic semiconductor. All the ionized

acceptors combine with free electrons of the donors and all the ionized donors combine with free holes of the acceptors to produce no net free carriers. For  $N_d^+ \neq N_a^-$  or simply  $N_d \neq N_a$  (donors and acceptors are assumed to be ionized), the semiconductor behaves as  $n$ -type or  $p$ -type depending on the relative magnitudes of  $N_d$  and  $N_a$ , and the cases described above become applicable.

## SOLVED EXAMPLES

**Example 7.1.** The electron and hole mobilities in a Si sample are 0.135 and  $0.048 \text{ m}^2/\text{V}\cdot\text{s}$  respectively. Determine the conductivity of intrinsic Si at 300 K if the intrinsic carrier concentration is  $1.5 \times 10^{16} \text{ atoms/m}^3$ . The sample is then doped with  $10^{23}$  phosphorus atoms/ $\text{m}^3$ . Determine the equilibrium hole concentration, conductivity and position of the Fermi level relative to the intrinsic level.

**Solution.** Given

$$\begin{aligned}\mu_n &= 0.135 \text{ m}^2/\text{V}\cdot\text{s} \\ \mu_p &= 0.048 \text{ m}^2/\text{V}\cdot\text{s} \\ n_i &= 1.5 \times 10^{16} \text{ m}^{-3}\end{aligned}$$

In the case of intrinsic semiconductors,

$$n = p = n_i$$

Therefore, the conductivity is given by

$$\begin{aligned}\sigma &= en_i(\mu_n + \mu_p) \\ &= 1.6 \times 10^{-19} \times 1.5 \times 10^{16} \times (0.135 + 0.048) \\ &= 4.39 \times 10^{-4} (\Omega\cdot\text{m})^{-1}\end{aligned}$$

In the extrinsic case, since  $N_d \gg n_i$ , and assuming all the donors to be ionized, we have

$$n \cong N_d^+ = 10^{23} \text{ atoms/m}^3$$

Therefore, the equilibrium hole concentration is

$$p = \frac{n_i^2}{n} = \frac{(1.5 \times 10^{16})^2}{10^{23}} = 2.25 \times 10^9 \text{ m}^{-3}$$

The conductivity is given by

$$\begin{aligned}\sigma &= en\mu_n \\ &= 1.6 \times 10^{-19} \times 10^{23} \times 0.135 \\ &= 21.6 \times 10^2 (\Omega\cdot\text{m})^{-1}\end{aligned}$$

From Eq. (7.42),

$$\begin{aligned}E_F - E_i &= kT \ln \left( \frac{n}{n_i} \right) \\ &= 8.62 \times 10^{-5} \times 300 \ln \left( \frac{10^{23}}{1.5 \times 10^{16}} \right) \\ &= 0.406 \text{ eV}\end{aligned}$$

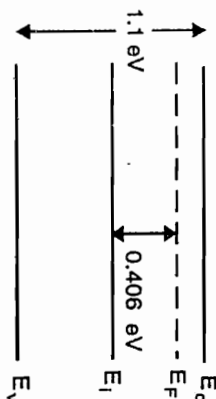

Fig. 7.11

The position of the Fermi level in the band diagram is shown in Fig. 7.11.

**Example 7.2.** In intrinsic GaAs, the electron and hole mobilities are 0.85 and  $0.04 \text{ m}^2/\text{V}\cdot\text{s}$  respectively and the corresponding effective masses are  $0.068 m_0$  and  $0.5 m_0$  respectively where  $m_0$  is the rest mass of an electron. Given the energy band gap at 300 K as 1.43 eV, determine the intrinsic carrier concentration and conductivity.

**Solution.** Given,

$$\begin{aligned}\mu_n &= 0.85 \text{ m}^2/\text{V}\cdot\text{s} \\ \mu_p &= 0.04 \text{ m}^2/\text{V}\cdot\text{s} \\ m_n^* &= 0.068 m_0 \\ m_p^* &= 0.5 m_0 \\ E_g &= 1.43 \text{ eV} \\ T &= 300 \text{ K}\end{aligned}$$

From Eq. (7.36), the intrinsic carrier concentration is given by

$$\begin{aligned}n_i &= 2 \left( \frac{2\pi kT}{h^2} \right)^{3/2} (m_n^* m_p^*)^{3/4} \exp \left( -\frac{E_g}{2kT} \right) \\ &= 2 \left[ \frac{2\pi \times 1.38 \times 10^{-23} \times 300}{(6.63 \times 10^{-34})^2} \right]^{3/2} \times \\ &\quad \times \left[ 0.068 \times 0.5 \times (9.1 \times 10^{-31})^2 \right]^{3/4} \exp \left( -\frac{1.43}{2 \times 8.62 \times 10^{-5} \times 300} \right) \\ &= 1.94 \times 10^{12} \text{ m}^{-3}\end{aligned}$$



The conductivity is given by

$$\begin{aligned}\sigma &= en_i (\mu_n + \mu_p) \\ &= 1.6 \times 10^{-19} \times 1.94 \times 10^{12} \times (0.85 + 0.04) \\ &= 2.76 \times 10^{-7} \text{ (}\Omega\text{-m)}^{-1}\end{aligned}$$

**Example 7.3.** The resistivity of an intrinsic semiconductor is 4.5 ohm-m at 20°C and 2.0 ohm-m at 32°C. What is the energy band gap?

**Solution.** For an intrinsic semiconductor, we have

$$\sigma = en_i \mu$$

Using Eq. (7.36), we get

$$\begin{aligned}\sigma &= 2e\mu \left( \frac{2\pi kT}{h^2} \right)^{3/2} (m_n^* m_p^*)^{3/4} \exp\left(-\frac{E_g}{2kT}\right) \\ &= CT^{3/2} \exp\left(-\frac{E_g}{2kT}\right)\end{aligned}$$

where  $C$  is a constant given by

$$C = 2e\mu \left( \frac{2\pi k}{h^2} \right)^{3/2} (m_n^* m_p^*)^{3/4}$$

If  $\sigma_1$  and  $\sigma_2$  are the conductivities at temperatures  $T_1$  and  $T_2$  respectively, then

$$\frac{\sigma_1}{\sigma_2} = \frac{\rho_2}{\rho_1} = \left( \frac{T_1}{T_2} \right)^{3/2} \exp \left\{ \frac{E_g}{2k} \left( \frac{1}{T_2} - \frac{1}{T_1} \right) \right\}$$

where  $\rho$  represents the resistivity. The above equation can also be expressed as

$$\frac{E_g}{2k} \left( \frac{1}{T_1} - \frac{1}{T_2} \right) = \ln \frac{\sigma_2}{\sigma_1} + \frac{3}{2} \ln \frac{T_1}{T_2}$$

Now, we have

$$\begin{aligned}T_1 &= 20 + 273 = 293 \text{ K}, & \rho_1 &= 1/\sigma_1 = 4.5 \text{ ohm-m} \\ T_2 &= 32 + 273 = 305 \text{ K}, & \rho_2 &= 1/\sigma_2 = 2.0 \text{ ohm-m}\end{aligned}$$

$$\therefore \frac{E_g}{2 \times 1.38 \times 10^{-23}} \left( \frac{1}{293} - \frac{1}{305} \right) = \ln \left( \frac{4.5}{2.0} \right) + \frac{3}{2} \ln \left( \frac{293}{305} \right)$$

$$\begin{aligned}\text{or } E_g &= 1.54 \times 10^{-19} \text{ J} \\ &= 0.96 \text{ eV}\end{aligned}$$

## SUMMARY

1. Semiconductors are materials which have electrical conductivity lying between those of conductors and insulators. They exhibit band gaps of the order of 1 eV and negative temperature coefficient of resistance. Examples of these materials are Si, Ge, GaAs, InP, CdS, etc.

2. In a semiconductor, two types of current carriers are present, viz., electrons and holes. Electrons conduct in the conduction band and holes conduct in the valence band.

3. In a pure or intrinsic semiconductor, electrons and holes are thermally generated and are equal in number.

4. In a doped or extrinsic semiconductor, the conduction is mainly by either electrons ( $n$ -type conduction) or holes ( $p$ -type conduction). The electrons in the  $n$ -type and holes in the  $p$ -type semiconductors are called majority carriers. The holes in the  $n$ -type and electrons in the  $p$ -type material are termed the minority carriers.

5. Mobility is the velocity acquired by a carrier in a unit electric field. Electrons have greater mobility than holes. Hence devices with  $n$ -type conduction are mostly preferred to those with  $p$ -type conduction.

6. In general, two types of currents flow in a semiconductor — the drift current and the diffusion current. The motion of carriers in an electric field constitutes the drift current. The diffusion current arises from the motion of carriers under the effect of concentration gradient of the carriers. In a uniformly doped semiconductor, the latter contribution is absent.

7. The conductivity of a semiconductor, in general, is given by

$$\sigma = e(n\mu_n + p\mu_p)$$

8. The conductivity of an intrinsic semiconductor increases with temperature. The plot of  $\ln \sigma$  versus  $1/T$  is a straight line and can be used to determine the band gap.

9. The concentration of electrons in the conduction band and holes in the valence band are given by the expressions

$$n = 2 \left( \frac{2\pi m_n^* kT}{h^2} \right)^{3/2} \exp \left[ - \left( \frac{E_c - E_F}{kT} \right) \right]$$

$$p = 2 \left( \frac{2\pi m_p^* kT}{h^2} \right)^{3/2} \exp \left[ - \left( \frac{E_F - E_v}{kT} \right) \right]$$

The intrinsic carrier concentration is

$$n_i = 2 \left( \frac{2\pi m_p^* kT}{h^2} \right)^{3/2} (m_n^* m_p^*)^{3/4} \exp \left( - \frac{E_g}{2kT} \right)$$

10. The law of mass action, i.e.,

$$np = n_i^2$$

holds for both intrinsic and extrinsic semiconductors.

11. In an intrinsic semiconductor, the Fermi level lies in the middle of the conduction band and the valence band edges. At moderate temperatures and impurity concentrations, the Fermi level of an  $n$ -type semiconductor lies almost in the middle of the donor level and the conduction band edge, whereas in a  $p$ -type semiconductor, it lies in the middle of the acceptor level and the valence band edge. As the temperature increases, the Fermi level approaches the intrinsic level.

### VERY SHORT QUESTIONS

1. What is an intrinsic semiconductor?
2. What is an extrinsic semiconductor?
3. Explain the concept of hole.
4. What type of carriers is present in a semiconductor?
5. Define mobility of a charge carrier.
6. What is doping?
7. Draw the energy level diagram for an  $n$ -type semiconductor and label it.
8. Draw the energy level diagram for a  $p$ -type semiconductor and label it.

9. What are majority carriers and minority carriers?
10. Define law of mass-action. For what type of semiconductors does it hold?
11. Define drift velocity of a carrier?
12. What are degenerate semiconductors?
13. Which has greater mobility, electron or hole?
14. Can a semiconductor containing both  $n$ -type and  $p$ -type impurities behave as intrinsic semiconductor? Give reason.  $N_D^+ = N_A^-$

### SHORT QUESTIONS

1. Give the properties of holes vis-a-vis electrons.
2. Explain the conduction mechanism for  $n$ -type and  $p$ -type semiconductors.
3. What are donors and acceptors? Give two examples of each.
4. Derive and discuss the law of mass action.
5. Explain the concepts of drift current and diffusion current. How are they different?
6. Obtain an expression for conductivity of an intrinsic semiconductor. How does it vary with temperature?
7. Show a typical variation of conductivity with temperature for an extrinsic semiconductor and explain the different regions.
8. Define the Fermi level. What is its importance in electronic grade materials?

### LONG QUESTIONS

1. Discuss the current conduction in semiconductors. How do conductivity of a semiconductor and a metal change with impurity content? Explain the difference in behaviour of these two materials due to change in conductivity.
2. Derive expression for density of free electrons and holes in an intrinsic semiconductor. Show that the Fermi level lies halfway between the valence band and the conduction band.
3. What is an extrinsic semiconductor? Discuss the variation of the Fermi level with temperature for an  $n$ -type semiconductor.

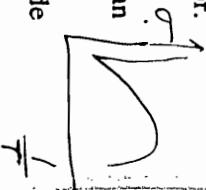

## Semiconductors

4. Derive an expression for density of electrons in the conduction band for an  $n$ -type semiconductor.
5. What are mobility and conductivity? Obtain an expression for conductivity of doped semiconductors.
6. Derive expressions for electron and hole concentrations for an intrinsic semiconductor. Use these results to obtain intrinsic carrier concentration.
7. Show that the product of electron and hole concentrations in a semiconductor is constant at a given temperature. How is the energy gap determined from the measurement of electrical conductivity of a semiconductor?

## PROBLEMS

1. An intrinsic germanium crystal has a hole density of  $10^{19} \text{ m}^{-3}$  at room temperature. When doped with antimony, the hole density decreases to  $10^{17} \text{ m}^{-3}$  at the same temperature. Calculate the majority carrier density.  $(10^{21} \text{ m}^{-3})$
2. The band gaps of diamond and silicon are 5.4 and 1.1 eV respectively. Estimate the temperature at which diamond has the same conductivity as Si at  $27^\circ\text{C}$ .  $(1200^\circ\text{C})$
3. The conductivity of intrinsic Si is  $4.17 \times 10^{-5}$  and  $4 \times 10^{-4} (\Omega\text{-m})^{-1}$  at  $0^\circ\text{C}$  and  $27^\circ\text{C}$  respectively. Determine the average band gap of Si.  $(1.11 \text{ eV})$
4. The conductivity of  $n$ -type germanium semiconductor is  $39 \Omega^{-1}\text{m}^{-1}$ . If the mobility of electrons in germanium is  $0.39 \text{ m}^2 \text{ V}^{-1}\text{s}^{-1}$ , then find the concentration of the donor atoms.  $(6.25 \times 10^{20} \text{ m}^{-3})$
5. How many donor atoms should be added per cubic metre of pure germanium crystal such that an  $n$ -type semiconductor is formed whose conductivity is  $500 \text{ mho/cm}$ . Given that the mobility of electrons in  $n$ -type semiconductor is  $0.385 \text{ m}^2\text{V}^{-1}\text{s}^{-1}$ .  $(8.12 \times 10^{24})$
6. The conductivity of a semiconductor changes when the concentration of electrons is varied by changing the position of impurity level. Show that it passes through a minimum when the concentration of electrons becomes  $n_i \sqrt{\mu_p / \mu_n}$  where  $n_i$  is the intrinsic carrier concentration,  $\mu_n$  and  $\mu_p$  represent the mobilities of electrons and holes respectively. Determine the minimum value of conductivity.  $(2ne\mu_n)$

7. The mobilities of electrons and holes in intrinsic Ge are 0.39 and  $0.19 \text{ m}^2/\text{V-s}$  respectively. Determine the intrinsic carrier concentration and conductivity of Ge at  $300 \text{ K}$  if the band gap of Ge is  $0.67 \text{ eV}$  and the effective masses of electrons and holes are  $0.55m_0$  and  $0.37m_0$  respectively,  $m_0$  being the electronic rest mass. How many dopants must be added per cubic metre of Ge to increase its conductivity by a factor of  $10^4$ ?  $(1.81 \times 10^{19} \text{ m}^{-3}, 1.68 \Omega^{-1}\text{m}^{-1}, 2.69 \times 10^{23} \text{ m}^{-3})$

8. In an  $n$ -type semiconductor, the Fermi level lies  $0.5 \text{ eV}$  below the conduction band. If the concentration of donor atoms is tripled, find the new position of the Fermi level, given  $kT = 0.03 \text{ eV}$ .  $(0.48 \text{ eV below the conduction band})$



Valence Band  $E_1$

Conduction Band  $E_2$

It just requires  $0.01\text{eV}$  to reach conduction band and become mobile.

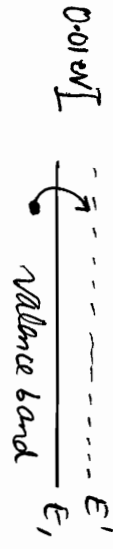

Acceptor type semiconductor  
 If acceptor level of energy  $E_1$  is in valence band, then electron from valence band fills it, leaving a hole. This hole becomes mobile.

It is widely used because: 1

- ① Stable and strong crystal structure like diamond.
- ② Capable of working at higher operating temperatures.
- ③ Cheap & abundant.

<https://ourstudycircle.in/>